

Inter-American Photochemical Society Newsletter



I-APS Internet Address <http://www.chemistry.mcmaster.ca/~iaps>

This newsletter is available in pdf format from the web site.

Volume 22 Number 1

May 1999

I-APS Officers	2
Letter from Linda Johnston, I-APS President.....	4
Announcements.....	5
Report on the Third International Congress of the Cuban Chemical Society	8
Report on the Workshop on Photosciences.....	14
The Solvated Electron.....	16
Recent Noteworthy Articles in Organic Photochemistry	21
6 th Latin American Encounters for Photochemistry & Photobiology (ELAFOT-6)—Fourth Circular	59
Upcoming Meetings	60
Registration Form for the I-APS	64

I-APS Officers

President

Linda J. Johnston
Steacie Institute for Molecular Science
National Research Council
Ottawa, ON K1A 0R6
ljj@ned1.sims.nrc.ca

Vice President

Frederick D. Lewis
Department of Chemistry
Northwestern University
Evanston, IL 60208-3113
lewis@chem.nwu.edu

Secretary

Russell H. Schmehl
Tulane University
Department of Chemistry
New Orleans, LA 70118
schmehl@mailhost.tcs.tulane.edu

Treasurers

Lisa Kelly
Department of Chemistry & Biochemistry
1000 Hilltop Circle
University of Maryland-Baltimore County
Baltimore, MD 21250
lkelly@umbc.edu

Cornelia Bohne
Department of Chemistry
University of Victoria
P.O. Box 3055
Victoria, B.C.
Canada V8W 3P6
bohne@uvic.ca

Miguel G. Neumann (South America)
Instituto de Quimica e Fisicade Sao Carlos
CP 369, Universidade de Sao Paulo
Sao Carlos, Sao Paulo CEP 13560
Brazil
neumann@iqsc.sc.usp.br

Advisory Committee

Cornelia Bohne
Department of Chemistry
University of Victoria, B.C.
P.O. Box 3055
Victoria, B.C.
CANADA V8W 3P6
bohne@uvphys.phys.uvic.ca

Frank H. Quina
Instituto de Química
Universidade de São Paulo
São Paulo, Brazil
frhquina@quim.iq.usp.br

Richard G. Weiss
Department of Chemistry
Georgetown University
Washington, DC 20057
weissr@gusun.georgetown.edu

Lisa McElwee-White
Department of Chemistry
P.O. Box 117200
University of Florida
Gainesville, FL 32611
lmwhite@chem.ufl.edu

Ian R. Gould
Department of Chemistry
Arizona State University
Box 871604
Tempe, AZ 95287-1604
igould@asu.edu

Irene E. Kochevar
Department of Dermatology
Massachusetts General Hospital WEL-224
Harvard Medical School
Boston, MA 02114
kochevar@helix.mgh.harvard.edu

Newsletter Editor

William S. Jenks
Department of Chemistry
Iowa State University
Ames, IA 50011-3111
wsjenks@iastate.edu
(515) 294-4711

I-APS Webmaster

William Leigh
Department of Chemistry
McMaster University
1280 Main St. West
Hamilton, ON L8S 4M1 Canada
Leigh@mcmaster.ca

April 20, 1999

Dear Colleagues,

Spring is finally here, even in Ottawa! I'm sure that everyone is looking forward to a busy and productive summer with opportunities to meet people at the many photochemistry conferences this year.

There has been activity on several fronts during the last few months and most of this is summarized elsewhere in the Newsletter. I would like to draw your attention briefly to several things. First of all please note the call for nominations for the I-APS 2000 Award and for Society Fellowship. I encourage all of you to consider nominating a deserving colleague for either the award or fellowship.

Some of you will recall that the profits from the first South American I-APS meeting were used to establish a fund to facilitate participation at the I-APS conference by young South American scientists. Frank Quina has prepared a draft document for the new Cilento Award with input from the Advisory Board. Thanks everyone for your work on this! Fred Lewis is in the process of establishing a committee to select the award winner and the first awardee will attend the next Winter Conference this coming January. More information on the Cilento Award can be found on the page with the call for award nominations.

Ed Hilinski and Joe Hupp have the plans for the 11th Winter Conference well underway. Ed has been working hard on the local arrangements and we will have a new and improved site (still in Clearwater Beach) this year. See the announcement on this and mark your calendars now for what promises to be our best meeting yet. Note that the meeting starts on Jan. 2, thus avoiding the more expensive rates over the New Year's weekend. Please encourage students and postdoctoral fellows to attend. The conference circular will have more details on student support for the meeting.

In closing, enjoy your summer and remember to make plans to be in Clearwater Beach for the 11th Winter Conference.

Linda Johnston

2000 I-APS Award in Photochemistry: Call for Nominations

The Inter-American Photochemical Society Award was established in 1988 to recognize outstanding contributions by members of the Society to the advancement of the photochemical and photophysical sciences. The award recognizes achievements during the last ten years. The 2000 I-APS Award will be presented at the Eleventh I-APS Winter Conference to be held in Clearwater Beach, Florida in January 2000.

Nominations should include a detailed justification that clearly outlines the nominee's scientific achievements during the last ten years, along with a curriculum vita and publications list. Seconding letters from colleagues familiar with the nominee's work are also helpful to the committee. All documents should be forwarded to the Chair of the Awards Committee at the address below. The deadline for receipt of nominations is August 1, 1999.

I-APS Fellowship: Call for Nominations

The society established the honor of Fellowship in 1993. Fellowship recognizes outstanding lifetime scientific achievements in photochemistry or contributions to either the science of photochemistry as a discipline or the furtherance of the society through service. Fellowship is limited to 4% of the membership of the Society and no more than two Fellows can be elected in a given year. Fellows may be requested to make a short presentation at the next Winter Conference and will receive a waiver of membership dues.

Nominations should include a statement describing the merit of the contribution to be recognized and should state clearly whether the award is for contributions in science or service. Seconding letters are not required, but may be submitted. Nominees should be members of the Society. Exceptions to this requirement require special justification by the nominator. All documents should be forwarded to the Chair of the Awards Committee at the address below. The deadline for receipt of nominations is August 1, 1999.

Cilento Award: Call for Nominations

The Cilento Award was established in 1999 to facilitate attendance at I-APS Conferences by scientists and students, age 35 or younger, working in Latin America. The award will provide Apex airfare and waiver of the conference registration fee. The awardee will present a short talk at the I-APS Conference. Applications for the Cilento Award should consist of a curriculum vitae, abstract of the proposed talk, indication of fluency in English, and, in the case of graduate or postdoctoral students, a letter of recommendation from the research advisor. The deadline for receipt of nominations is October 1, 1999.

Nominations for the I-APS Award, I-APS Fellowship, and the Cilento Award should be sent to:

Frederick D. Lewis
I-APS Vice-President
Department of Chemistry
Northwestern University
Evanston, IL 60208-3113

I-APS Electronic Distribution Lists

Electronic mail distribution lists have been created for general announcements to all I-APS members. The lists have been set up as one-way electronic mailings and are being maintained by Professor Mary Boyd at Loyola University of Chicago. If you have an announcement of interest to the general membership (e.g., postdoc openings, job postings, conference announcements), please send an e-mail message to mboyd@luc.edu and the message will be sent to the membership.

If you have not been receiving these irregular mailings or have recently changed your email address, please forward your new address to Professor Boyd so that she may get you added to the list.

Eleventh Inter-American Photochemical Society Winter Conference

**Clearwater Beach, Florida
January 2-6, 2000**

Please note that the dates have been changed from those given in the November 1998 Newsletter as a result of several unique situations presented by Year 2000 New Year Celebrations.

Co-Chairpersons

Dr. Edwin F. Hilinski
Florida State University
FAX: 850-644-8281
E-mail: hilinski@chem.fsu.edu

Dr. Joseph T. Hupp
Northwestern University
FAX: 847-492-7713
E-mail: jthupp@chem.nwu.edu

Organizing Committee

Mary K. Boyd
M. Glenn Horner
Irene E. Kochevar

Mostafa A. El-Sayed
Linda J. Johnston
Russell H. Schmehl

John R. Scheffer

This Winter Conference will take place at a new site located near the end of the causeway leading to Clearwater Beach: the Hilton Clearwater Beach Resort at 400 Mandalay Avenue, Clearwater Beach, Florida 33767

Registration and a reception will take place in the evening on Sunday, January 2, 2000.

The scientific sessions will begin the morning of January 3 and end at noon on January 6.

For more information, go to the Inter-American Photochemical Society web site at <<http://www.chemistry.mcmaster.ca/~iaps/>> and click on the link for this conference.

Third International Congress of the Cuban Chemical Society

Report of a trip to Havana by a delegation from the American Chemical Society

Morton Z. Hoffman, Boston University, Boston, MA 02215-2521

A ten-person delegation from the American Chemical Society traveled to Cuba to attend the Third International Congress of the Cuban Chemical Society held December 1–4, 1998, in Havana. The delegation consisted of Dr. Paul H. L. Walter (1998 ACS president), Dr. John M. Malin (ACS staff for international activities), William G. Schulz (*C&EN* news editor), Prof. Ernest L. Eliel (University of North Carolina–Chapel Hill, and ACS past-president), Prof. Zafra M. Lerman (Columbia College, Chicago, IL), Prof. Pratibha Varma–Nelson (Saint Xavier University, Chicago, IL), Prof. Babu George (Sacred Heart University, Fairfield, CT), Prof. Morton Z. Hoffman (Boston University, MA), Prof. Gabriel A. Infante (Pontifical Catholic University, Ponce, Puerto Rico), and Dr. David A. Katz (chemical education consultant, Philadelphia, PA).

The meeting, cosponsored by the International Union of Pure and Applied Chemistry and a number of international chemical companies, such as Merck (Germany), Micromass (U.K.), Amersham/Pharmacia (U.K.), and Sumerian Ventures (Canada), was attended by more than 400 chemists, mainly from Cuba, the Caribbean, and Latin America; small groups from Canada and Europe were also in attendance. In addition to plenary lectures, oral and poster papers were presented in the areas of chemical education, agricultural chemistry, industrial chemistry, medicinal chemistry, biological chemistry, environmental chemistry, general chemistry, and the history of chemistry. Special symposia on chromatography and process scale-up were also held. Although the official languages of the conference were Spanish and English, almost all the talks, posters, and abstracts were presented in Spanish.

Oral presentations were made by the members of the ACS delegation. Ernest Eliel, who had emigrated with his family from Germany before World War II to the United Kingdom but during the war had been sent to Canada and then onto Cuba, arriving in Havana all by himself at the age of 19, received his bachelor's degree in chemistry at the University of Havana in 1946; he gave his plenary lecture in Spanish, "La Sociedad Americana de Química y la Enseñanza de la Química en Nivel Medio y Primario en los EE.UU." ("The American Chemical Society and Chemistry Teaching in Primary and Secondary School in the U.S.A."). He also co-chaired the sessions on chemical education at which other members of the group gave talks: George on "Chemical Education - A True Collaboration Between the University and Elementary, Middle and High Schools," Varma–Nelson on "Workshop Chemistry Project: Peer–Led Team Teaching," Hoffman on "Using Electronic Mail in Undergraduate Education," Katz on "Active Assessment: Menus and Hands–on Questions," Lerman on "Teaching Environmental Science to Non–Science Majors," and Malin on "ACS International Activities." Paul Walter's talk emphasized the importance of building relationships between Cuban and American chemists through their national chemical societies. Infante, who was born in Cuba and is president of the Latin American Federation of Chemical Associations, gave his talk in Spanish in the environmental chemistry session: "Detección de Orgánicos Volátiles y Metales Pesados en Aguas Subterráneas Circundantes a un Vertedero de Desperdicios Sólidos" ("Detection of Organic Volatiles and Heavy Metals in Surrounding Groundwaters of a Solid Waste Site"). Schulz served as the press liaison for the ACS group; his articles on the meeting were published in the December 14, 1998, and January 11, 1999, issues of *C&EN*.

The trip by Walter, Malin, Schulz, and Eliel was organized through the ACS in Washington. The trip by the others, who are all members of the Division of Chemical Education (DivCHED), was organized by Lerman in her role as chair of the DivCHED International Activities Committee; she also serves on the ACS International Activities Committee, where she chairs the Subcommittee on Scientific Freedom and Human Rights. Hoffman, George, Varma–Nelson, and Infante are also members of the DivCHED International Activities Committee.



Fig. 1. ACS delegation in Havana: (left to right) Babu George, Morton Hoffman, Ernest Eliel, Gabriel Infante, Zafra Lerman, David Katz, John Malin, Paul Walter and Pratibha Varma-Nelson.

Our trip to Havana has to be put into the perspective of the past and present status of U.S.–Cuban relations. The successful revolution for independence from Spain led by José Martí more than 100 years ago, the Spanish–American War ("Remember the *Maine!*"), and the expansion of American economic, political, and military interests in the Caribbean early in the 20th Century caused Cuba to come under strong U.S. influence. The government of Cuba protected U.S. investments in agriculture, industry, and tourism, resulting in the development of a heady mixture of corruption, gambling, and crime. By the 1950's, with Batista as president of Cuba, Havana had become the nearby off–shore "sin city" for Americans. In 1959, Fidel Castro staged his successful revolution, overthrew the old regime, instituted a communist government, nationalized private investments, and instituted socialized agrarian reform. We all know of the ill–fated Bay of Pigs invasion in 1961 and the successful resolution (thank God!!) of the U.S.–Soviet missile crisis of 1962.

As a result of these actions, diplomatic relations between the U.S. and Cuba were severed and the U.S. imposed an economic embargo. Travel by Americans to Cuba was forbidden until recently, but the economic embargo, requiring that no money be spent in Cuba by Americans, is still in effect. Traveler's checks and credit cards issued by U.S. banks (such as American Express) are not accepted in Cuba, but, interestingly, U.S. currency is legal tender with all prices given in \$.

In order to go to Cuba legally, it is necessary to obtain a license from the Treasury Department, which is issued for a specific purpose and for a well-defined period of time. The only people permitted to travel, albeit under careful regulation, are journalists, governmental officials, members of international organizations, those with close relatives in Cuba, and others, such as our group, who have a need to travel there. A license permits the visitor to spend up to \$100 per day in Cuba for living expenses (lodging, transportation, and meals); up to \$100 of Cuban goods (such as cigars and rum) can be brought back for personal use, although informational materials (books, films, tapes, CDs) may be transported freely. The U.S. government is not minimizing the seriousness of the economic embargo; criminal penalties for violating the regulations range up to 10 years in prison and \$250,000 in fines in addition to civil penalties of up to \$55,000 per violation. That illegal box of Cuban cigars can cost one dearly; it must be remembered that customs officers at the U.S. points of entry are members of the Treasury Department, and possess all the zeal of Elliott Ness and "The Untouchables."

The initial application for a license from ACS earlier in 1998 was denied by the Treasury Department; extensive negotiations with the State and Treasury Departments, and desperate last-minute appeals to U.S. legislators finally led to the issuance of the required license for the DivCHED group on November 23, three days before the long Thanksgiving holiday and only one week before the members were to travel. By that time, abstracts of papers had been submitted and full payment for the trip had been made.

Because of the embargo, it is not possible to buy a plane ticket to Cuba in the U.S. nor travel directly (except for nonscheduled charter flights from Miami). We were advised to fly to Havana from Cancun, Mexico, on Air Caribe, a regional carrier associated with Mexicana Airlines, so as to avoid travel on Cubana Airlines, which operates Soviet-vintage aircraft. Working through the travel agent that deals with Cuba (Marazul Tours, Weehawken, NJ), we were able to obtain our vouchers for the flight tickets to Havana (to be exchanged in Cancun), vouchers for the hotel (including breakfast and dinner) and ground transportation, and Cuban entry visas in exchange for a fax copy of our license. We had all our documents in hand by Thanksgiving eve.

It should be pointed out that it is possible for Americans to travel to Cuba without a license, and thousands do so each year. Travel agents in the Caribbean can arrange prepaid excursions from their points of departure; the Cuban immigration officials understandingly will not stamp a U.S. passport unless they are asked to do so. As a result, one can go to Cuba without anyone being the wiser. However, one must not attempt to bring goods of Cuban origin back into the U.S.

Lerman, Katz, George, and Varma-Nelson left the U.S. on November 30 to rendezvous in Cancun with Infante, who flew there from Puerto Rico via Miami! Because of their arrival in the morning and the evening departure of the flight to Havana, they were able to luxuriate in a Cancun hotel and sip margaritas at poolside. The first indication of the failure of our best laid plans occurred that evening when the group gathered for their flight to Havana. Because Infante had been born in Cuba, he needed a different visa than the one the travel agent provided. As a result, he had to remain in Cancun until the next day in order for the proper visa to be prepared.

Because of his commitments in Boston, Hoffman could not leave until December 1; he arrived in Cancun early in the afternoon, and barely survived more than seven hours in the transit lounge at an airport where there are no smoke-free zones. The resulting hardening of the bronchial membranes was good preparation for the absence of smokeless air in the interior space in Havana. The flight from CUN to HAV, which finally left one hour late, was thankfully short (40 minutes) and uneventful; however, seat assignments and any regulations on the number and size of the bags, boxes, and cartons that could be carried onto the plane were meaningless. Compared to the bright lights of Cancun upon departure, relative darkness surrounded the Havana area upon arrival; we were told that there are restrictions on the use of electricity at night due to limitations on its generation. The new Canadian-built

international terminal at the José Martí Airport, which has been operational for less than a year, is quite attractive and functional, with (thankfully) clean restrooms; our entry into Cuba was swift and effortless. Representatives from Havanatur met the arriving passengers who had ground transportation vouchers, and provided a slow (~1 hour), bumpy (the roads are in terrible condition), 15-mile ride (with hardly any other traffic in sight) into Havana, complete with a narrator named Ivan who described the sights and extolled the virtues of the Cuban communist way-of-life.

We stayed at the conveniently-located Hotel Ambos Mundos in Old Havana, only a short walk to the beautiful cathedral, the bustling outdoor markets, and the esplanade that runs along the river channel that connects the Atlantic Ocean with Havana Bay. The hotel, built in the 1920's but with recently renovated bathrooms, has a spacious and comfortable lobby, an antique cage elevator with a mind of its own, an attractive rooftop restaurant with reasonable food but a very limited menu, and musty rooms with incredibly high ceilings. The hallways were very dark at night, the television sets in the rooms were not necessarily operational, but the staff was efficient, helpful, and pleasant. It was possible or not, depending on whims we could not fathom, to dial the U.S. directly from the rooms; calls cost \$3 per minute. The services of American telephone companies, such as AT&T, MCI, and Sprint, which are accessible toll-free from almost every other country in the world, are not available from Cuba. It is much less expensive to call Cuba from the U.S.; the country code is 53 and the city code for Havana is 7. The pride of the Ambos Mundos is Room 511, where Ernest Hemingway often stayed in the 1930's; *For Whom the Bell Tolls* was written there.



Fig. 2. The Capitol of Cuba.

A 15-minute walk through the crowded, dusty, and narrow streets of Old Havana brought us into the central part of the city with its attractive buildings and distinguished hotels, grand theaters, and fine museums along broad and gracious boulevards. The meeting was held in "El Capitolio," the capitol building, which was modeled

after the corresponding building in Washington, DC, and built in the 1920's at a time when the words "handicap access" were not in the vocabulary. Fifty-five tall steps separate the street from the entrance, which didn't pose too much of a problem to us in the relative cool of the morning but seemed to grow higher in the heat of the afternoon, especially after a long, leisurely, and filling lunch.

The plenary sessions, which included a lecture on x-ray crystallography by American Nobel Laureate Herbert Hauptman, were held in one of the formal legislative chambers; the technical sessions were held in various conference rooms. The sessions on chemical education were well attended; our papers, although presented in English, attracted great interest. Because all of us were linguistically-challenged and communicatively-disadvantaged in Spanish, there was not very much public discussion of our presentations, although worthwhile conversations were carried out afterward in English on an individual basis. Business cards were exchanged, promises were made to establish e-mail communications, and hopes were expressed for future meetings. Above all, we all looked forward to the time, hopefully within a few years, when relations between Cuba and the U.S. would be normalized, and regular contacts between scientists of both nations could be established.

We were able to spend the good part of a day touring Havana in private cars. We visited the Spanish forts that line the entrance to the harbor, roamed around street markets with their endless array of inexpensive hand-crafted goods and hustlers peddling cigars of dubious origin, and saw monuments to the victims of the revolution against Spain, the explosion in the *USS Maine*, and the student revolt against Batista. We passed the campus of the University of Havana, viewed the exhibit of tanks, missiles, and boats from Castro's victories, and saw the building that houses the U.S. Interest Section, which is an embassy in everything but name. All these details were immortalized on many rolls of film.

We had to be at the airport two hours before the departure of our 7:10 a.m. flight to Cancun on December 5; fortunately, the 4 a.m. pickup at the hotel by Havanatur was more-or-less on time. Despite the fact that one of our group (the same person who had almost choked on a fish bone the previous day!) had lost the visa stub that was needed to get out of Cuba and had to do some fancy talking to avoid being forced to spend a couple of weeks in police custody, we all made it safely back to Cancun, had our bags searched for drugs (none found!), and dispersed for our flights to the U.S. Entrance back into the country occurred under the watchful eyes of the customs officials, who regarded us (and our Cuban cigars) with great suspicion and no small amount of hostility despite our Treasury Department license.

We returned with some indelible impressions about Cuba. In the first place, it's a much larger country than we imagined; it is almost 800 miles long with 11 million inhabitants, being the third largest non-continental island in the world (can you name the other two?). Havana displays some absolutely breathtaking Spanish colonial architecture, beautiful vistas, and a pleasant ambiance, but far too many outrageously ugly Soviet-style buildings. There are world-class luxury hotels and grim apartment high-rises; there are the gleaming American automobiles from the 1950's (when's the last time you saw a Studebaker, a Packard, and an absolutely knock-your-socks-off red and white Chevy Impala convertible with round tail lights atop the fins?) and also the long queues of people dutifully awaiting the arrival of overcrowded "camel" buses. There are the friendly, beguiling people, and there are the beggars who thrust infants in the faces of tourists and demand money for milk. In short, there is great wonder and beauty amidst a seriously decaying infrastructure. We could not but hope that the future will be kinder than the past has been to the people of Cuba.

All in all, it was a fascinating trip to a meeting that had great breadth, demonstrating that chemistry, and especially chemical education, is alive and well in Cuba. We tried to meet and build relationships with our Cuban colleagues toward the time, which we hope will be in the short-term future and not in the long run, when we will no

longer be isolated from one another. The visits to Cuba by Sen. Christopher Dodd (D-Conn.) and Rep. Barbara Lee (D-Calif.) and their entourages, which included meetings with Castro, while we were in Havana make us feel optimistic that the straws of détente are blowing in the wind. We hope that the recently-announced changes in the U.S. policy toward Cuba, including the establishment of direct mail service, more charter flights, and major league baseball exhibition games, are harbingers of better things to come.

For those who like to plan ahead, the next International Congress of the Cuban Chemical Society will be held in Havana on April 17-20, 2001. Perhaps by then it will be possible to fly directly from the U.S. to Cuba on a scheduled airline, and visit that country without battling an economic embargo.

Workshop on Photosciences
Taller de Fotociencias
University of Habana, Cuba, February 15-19, 1999

Silvia E. Braslavsky
Max-Planck-Institut für Strahlenchemie
Postfach 10 13 65, 45413 Mülheim an der Ruhr
Germany
Fax: +49 (208) 306-3951
e-mail: braslavskys@mpi-muelheim.mpg.de

This first workshop on photosciences in Cuba was organized by a committee headed by Dr. Elena Vigil from the Institute of Materials and Reagents (IMRE) of Habana University. The meeting was opened by a wonderful concert in the main Aula of the University which included some typical Cuban music, followed by welcome words from University officers.

The meeting offered for the first time the possibility of exchanging ideas to all scientist working in Cuba on the various aspects of the interaction of light and matter, from basic research to applied projects. During the first day, from 12:45 to 3 pm, each of the various Cuban groups briefly introduced its work which was fully presented in the posters shown on Tuesday and Wednesday. The various aspects of the work on photosciences in Cuba were displayed, from development of commercial lasers for surface cleaning and etching, analytical spectrometric devices for the measurement of sugar content in sugar refineries, and polarimeters for the sugar and pharmaceutical industry, to photobiological work with algae, plant physiology research, photoelectrochemistry with semiconductors, and theoretical work on pyrrolic macrocycles, as well as some work on laser therapy of sport injuries, and photonics and medicine in general, just to mention only some of the work presented in the *ca.* 60 posters.

The lectures program which included foreign and Cuban researchers was (in presentation order): **S.E. Braslavsky**, Germany: 'Photoinduced protein movements in biological photoreceptors,' **E. Clementi**, Universite Louis Pasteur, Paris: 'Revisiting the Hartree-Fock method for atoms and molecules,' **A.C. Albrecht**, Cornell University, USA: 'On the mechanism of ionization in molecular liquids,' **J. Bornman**, Lund University, Sweden: 'Plant response to an increasing UV-B radiation environment,' **Y.L. Chow**, Simon Fraser University, Canada: 'The role of acids in excited state reactions,' **N. Davidenko**, Universidad de la Havana: 'Radical photopolymerization of biopolymeric materials and compounds,' **V.B. Henríquez Pérez**, Cubasolar: 'Renewable energy sources and social impact,' **F. Lenci**, Institute of Biophysics, CNR, Italy: 'Photomovements in ciliates: photoreceptors and photosensory transduction,' **D. Meissner**, Applied Quantum Solar Energy Research, Germany: 'Organic solar cells,' **L. Montero**, University of Havana: 'Theoretical models for the photophysical and photochemical behavior of α -diketones,' **A. Moore**, Arizona State University, USA: 'Construction of artificial photosynthetic membranes for the study of solar energy conversion processes,' **C.R. Castellanos**, University of Havana: 'Nanostructures under the action of intense laser radiation,' **R. Rodés**, University of Havana: 'Biogenesis of the photosynthetic apparatus in sugar cane,' **M. Velázquez** and **H. Méndez**, Instituto Venezolano de Investigaciones Científicas, Venezuela: 'Photolability and phototoxicity studies of diuretic drugs. Photosensitizing properties of Triamterene,

Hydrochlorothiazide, Furosemide, Acetazolamide, and Chlorthalidone,' **S.E. Braslavsky**: 'Photothermal methods applied to the study of photoinduced reactions in solution.'

F. Lenci met with a group of Faculty members and students of Physics to discuss possible cooperation projects in the area of Biophysics. Closing the meeting, the President of the Cuban Academy of Sciences spoke to the participants and a round table discussion served to make a balance of the meeting and to outline the possibilities of cooperation with laboratories in industrialized countries. **F. Lenci** transmitted the readiness of the Association Internationale de Photobiologie (AIP) as expressed by its President, Pill-Soon Song, of helping the scientists in Cuba to develop a broad research capability in Photobiology. AIP was one of the sponsors of the workshop.

A program of visits to various laboratories and institutes was organized for the foreign participants. During those visits we had the opportunity of talking with young group leaders and to learn about the creative initiatives of the Cuban colleagues to counteract the great difficulties confronted by the Cuban industry and the society at large. Some of us visited Cubasolar, a non-governmental organization which aims at expanding the use of renewable energy sources in order to replace fossil fuels, among several objectives. Cubasolar also intends to educate people through the training of teachers in the better use of renewable energy sources. I was personally impressed by the activities of this organization who also publishes a Journal for the general public. One of the main activities of Cubasolar at the moment is the implementation of a large number of fully self-supported (in terms of energy and food) schools in the countryside, as well as solar energy-supported medical offices in the far corners of the mountains.

By talking with our Cuban colleagues as well as to Cubans in the streets, shops, and bars we learned a great deal about the difficulties brought by the embargo and by the sudden changes in the world political conditions in the 90's. But learning about the inventions and creations of our Cuban colleagues in order to develop their society in spite of those difficulties was an extraordinary experience, especially having in mind the difficulties of all Latin-American Countries to develop independent and autonomous economic and research activities. In the midst of those difficulties the Cubans managed to organize a wonderful meeting which, most of all, served to create a sort of photosciences Cuban community which should help expanding the research in this (we know) so important area of scientific and technological activity.

Needless to say that we (the non-Cubans) used every free minute to enjoy the corners of old Habana, the cafes and libraries, to get a ride in a Chevy or Oldsmobile from the 50's, to listen to the rumbas and boleros, and to drink a mojito and a daikiri in the bars Hemingway used to visit. Old Habana is a wonderful City and our Cuban colleagues made us feel really at home.

The Solvated Electron

Christine M.R. Clancy and Malcolm D.E. Forbes
Department of Chemistry
The University of North Carolina at Chapel Hill
Chapel Hill, NC 27599

The first observation of a solvated electron in 1864 was of the ammoniated electron¹ $e_{\text{NH}_3}^-$, though this species was not identified as such until 1908.² The existence of the hydrated electron e_{aq}^- was not proposed until the early 1950s³ and was definitively characterized in 1962 by pulse radiolysis transient absorption studies of Na_2CO_3 in water.⁴⁻⁶ The solvated electron, and especially the hydrated electron, has since been determined to be an extremely important reactive species.⁷ Because it is the simplest electron donor, and all of its reactions are in essence electron transfer reactions, the solvated electron's reactivity may be used to probe the electron transfer properties of acceptors. The solvated electron has been found to be useful in organic and inorganic chemistry by being used to create other reducing agents that are themselves less reactive and thus more selective, such as Zn^+ , Cd^+ , CO^{2-} , CO^- , and NO^- , to reduce nitrobenzene, to form nitrosobenzenehydrates, to oxidize organic compounds in the presence of molecular oxygen, and to produce short lived nitrogen acids.^{7,8} Solvent effects on the reactivity of e_{solv}^- have also been observed, which may be useful in studying reaction mechanisms.⁹⁻¹² Biological systems are also affected by the presence of hydrated electrons, and there is evidence that e_{aq}^- has a role in radiation-induced damage of enzymes and DNA.^{13,14}

Three important properties associated with the e_{solv}^- are its solvation dynamics, its solvation environment and its optical transition. These topics are not completely separable. For example, the transition of an electron from being unsolvated (e.g. an electron in an n orbital prior to photoionization) to being fully solvated is naturally a function of the properties of the solvent molecules into which it is entering, so solvation dynamics are a function of the solvation and pre- or partial solvation environments and solvation energies. The third issue, the photoexcitation of the solvated electron from its ground state into an excited state, is also connected. Information from optical studies of the electron provide information about these ground and excited states, and the ground state is described by the electron's solvation environment and the excited state may be a good picture of an intermediate state before complete solvation.¹⁵ It is clear that exploration of all three concepts are helpful and necessary for characterization of the solvated electron.

Hart and Anbar⁷, have presented a detailed history of the characteristics and the chemistry of the hydrated and solvated electron, and a number of reviews and other texts are also available.¹⁶⁻²⁰ A solvated electron may be produced by pulse radiolysis, γ -ray photolysis, photoionization of a molecule, or solvation of a metal. The process by which an electron becomes truly solvated has been and continues to be a topic of great interest, and much experimental and theoretical effort has been spent in unravelling it.^{15,17,21-37} Consideration of the process by which the potential well that the electron occupies in the solvent is created led to the creation of two schools of thought. The first viewed the solvation process as the electron creating its own potential well by polarizing the solvent around itself as it is solvated.⁷ The second favored the existence of pre-existing electron traps in the solvent which then serve as sites for localization of any electron with enough energy to be solvated.³⁸ However, a fusion of these views has come to be seen as the better physical description, and may be described by the scheme¹⁵:

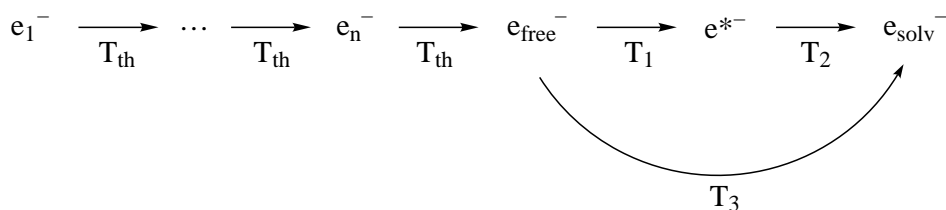

where e_1^- through e_n^- are different delocalized excited eigenstates having less energy as n increases; e_{free}^- is the quasi-free state, a low energy eigenstate that is ready to be solvated without further energy loss; e^{*-} , the “wet” electron, is a p-like localized state similar to the excited state of the solvated electron; e_{solv}^- is the completely solvated electron; and the T_k are the appropriate lifetimes. The term wet electron is used to distinguish this intermediate state from that of the fully solvated electron. Important features of this scheme include that there are multiple intermediate states between the delocalized, unsolvated electron e_n^- and the fully solvated electron e_{solv}^- , and that the quasi-free electron can bypass the wet state to become completely solvated.

The solvation environment of a solvated electron is considered to be the nature of the potential well in which the electron resides. Questions of interest include: What are the orientations of the solvent molecules around the electron? How many solvent shells does the electron effect the orientation of, or how “deep” does the electron’s polarizing charge penetrate into the solvent? How much space does the electron occupy, or what is its radius? At what rate do the solvent molecules that constitute the cavity exchange? If multiple solvents are present, does the electron solvate preferentially in one over the others? The solvation environment will be greatly determined by the solvation energy. For example, in the case of this last question in terms of binary solvent systems, there is evidence both for preferential solvation of the electron by the more polar solvent in some systems, and for a sort of intermediate environment, such that smooth transitions of the optical spectrum occurs upon changing of the mole fractions.^{19,39,41,40-43}

Absorption spectra of solvated electrons are broad, featureless, but very intense absorption bands ranging from the visible (~500-700 nm for alcohols and aqueous systems) to the infrared (up to 2,000+ nm for wet electrons, hexamethylphosphoric triamide) depending on the solvent and whether or not the electron is completely solvated.^{7,16-19} The electronic transition is the promotion of the solvated electron from its ground state to an excited state. In its ground state, the electron resides in a 1s-like state, and in the excited state the electron resides in a 2p-like state.⁴⁴⁻⁴⁹ The photoexcitement of a solvated electron from its ground state to available excited states is also an area of intense research, with models and methods often tested by simulation of absorption spectra.^{15,32,49-53} The absorption spectra are functions of the solvent and the conditions (temperature, pressure)^{21,30,42,54,55}, and are not affected by the method by which the solvated electrons are created (photolytically, radiolytically, or chemically).⁷ However, it has also been reported that the absorption spectrum of the solvated electron at room temperature is independent of pH, with a λ_{max} at 720 nm found for pH’s of 7, 11, and 12^{54,56-58}, and that reactivity of the hydrated electron is also unaffected by pH.⁷ Absorption spectra of electrons solvated in methanol and 2-propanol have the same general features of those of the hydrated electron, but the λ_{max} in methanol is ~620 nm, and in 2-propanol is ~810 nm²⁴, and in general different solvents show different λ_{max} ’s.^{19,21,30,39,59} An increase in temperature tends to lower the λ_{max} of the solvated electron in water, methanol, and ammonia. The presence of inert salts such as Li^+ , Na^+ , I^- and Cl^- shift the λ_{max} to shorter wavelengths, indicating a deepening of the potential well that the electron rests in resulting from a change in the structure of water due to the solvation of the salt ions.⁶⁰⁻⁶² However, comparison to absorption spectra of electrons in solid salts show that even at 15 M salt concentrations in water, the hydrated electron’s environment is dominated by “normal” water molecules.⁷

Steady state electron paramagnetic resonance (EPR), electron-nuclear double resonance (ENDOR) and electron spin-echo modulation (ESEEM) experiments of F-centers in alkali halide salts (electrons located in defects of a crystal lattice), hydrated electrons in neutral and basic water, ammoniated electrons, and trapped electrons in these same media have not only confirmed the existence of the solvated electron, but supported the evidence for its structure obtained by optical experiments.⁷ Single lines centered near but slightly less than the free electron g-factor of 2.0023 in these different media confirm similar solvation environments. EPR linewidths of the electron in water tend to decrease with increasing temperature, indicating fast motion of the water molecules' hydrogen atoms (and thus of the water molecules). This is also indicative of an electron residing in a cavity lined by hydrogen atoms of water molecules that are being replaced or exchanged at a fast rate. Linewidth analysis of electrons trapped in frozen H₂O and D₂O show that the width of the electron's single EPR transition can be accounted for by hyperfine coupling between the electron and protons (or deuterons) of six roughly octahedrally coordinated water molecules.^{63,64} However, studies of the solvated electron in liquid solutions imply an exchange rate of ~100 ps for molecules making up the electron's cavity.⁶⁵

Another feature of the solvated electron is the size of the cavity it occupies within the solvent, where the cavity is essentially a place without solvent molecules and with the electron. Molecular dynamics calculations of the hydrated electron find the radius of the first solvation shell to be 4.0 Å, with an average of 6.2 water molecules, and the second solvation shell radius to be 7.5 Å with an average of 50.3 water molecules.⁴⁸ Square-well potential models applied to absorption spectra have estimated the effective radii for the solvated electron at: NH₃ 3.66 Å, H₂O 2.10 Å, and EtOH 2.08 Å.²² Results from other methods show this is a lower limit, and that a more realistic radius is 2.5 Å.⁵¹ Also, these methods find the radius of the ammoniated electron to be ~2.8-3.66 Å.⁷

Future work studying the solvated electron will continue to focus on the three issues discussed above. Simulations of the process of solvation and comparison of these simulations to faster, better resolved optical spectra are a leading area of research into these areas. Computer modeling and simulations of the photoexcitation of the solvated electron should continue to yield important information about the solvation process and the solvation environment.

REFERENCES

- 1) Weyl, W. *Pogg. Ann.* **1864**, 123, 350.
- 2) Kraus, C. A. *J. Am. Chem. Soc.* **1908**, 30, 1323.
- 3) Stein, G. *Disc. Faraday Soc.* **1952**, 12, 227.
- 4) Hart, E. J.; Boag, J. W. *J. Am. Chem. Soc.* **1962**, 84, 4090.
- 5) Boag, J. W.; Hart, E. J. *Nature* **1963**, 197, 45.
- 6) Dainton, F. S. ; Ebert, M. and Howard, A., Ed.; *Radiation Effects in Physics, Chemistry and Biology*. North-Holland Pub. Co: Amsterdam, 1963, p. 34.
- 7) Hart, E. J.; Anbar, M. *The Hydrated Electron*; Wiley-Interscience, 1970.
- 8) Henglein, A. *Ber. Bunsenges. Phys. Chem.* **1971**, 75, 622.
- 9) Senanayake, P. C.; Freeman, G. R. *J. Phys. Chem.* **1988**, 92, 5142.
- 10) Chen, R.; Freeman, G. R. *Can. J. Chem.* **1993**, 71, 1303.
- 11) Chen, R.; Avotins, Y.; Freeman, G. R. *Can. J. Chem.* **1994**, 72, 1083.
- 12) Zhao, Y.; Freeman, G. R. *Can. J. Chem.* **1995**, 73, 284.

- 13) Bent, D. V.; Hayon, E. *J. Am. Chem. Soc.* **1975**, *97*, 2599.
- 14) Jovanovic, S. V.; Harriman, A.; Simic, M. G. *J. Phys. Chem.* **1986**, *90*, 1935.
- 15) Keszei, E.; Murphrey, T. H.; Rossky, P. J. *J. Phys. Chem.* **1995**, *99*, 22.
- 16) Feng, D.-F.; Kevan, L. *Chem. Rev.* **1980**, *80*, 1.
- 17) Schindewolf, U. *Angew. Chem. Int. Ed. Engl.* **1978**, *17*, 887.
- 18) Webster, B. C. *Annu. Rep. Prog. Chem. Sec. C* **1979**, *76*, 387.
- 19) Kevan, L.; Webster, B. C. *Electron-Solvent and Anion-Solvent Interactions*; Elsevier Scientific Publishing Company: Amsterdam, 1976, p. 360.
- 20) Tuttle, T. R., Jr.; Golden, S. *J. Phys. Chem.* **1991**, *95*, 5725.
- 21) Douthit, R. C. *J. Am. Chem. Soc.* **1960**, *82*, 4472.
- 22) Blandamer, M. J.; Catterall, R.; Shields, L.; Symons, M. C. R. *J. Chem. Soc.* **1964**, 4357.
- 23) Dainton, F. S. *Ber. Bunsenges. Phys. Chem.* **1971**, *75*, 608.
- 24) Sauer, J., M.C.; Arai, S.; Dorfman, L. M. *J. Chem. Phys.* **1965**, *42*, 708.
- 25) Tachiya, M.; Watanabe, M. *J. Chem. Phys.* **1977**, *66*, 3056-3060.
- 26) Walker, D. C. *J. Phys. Chem.* **1980**, *84*, 1140.
- 27) Chandler, D. *J. Phys. Chem.* **1984**, *88*, 3400.
- 28) Migus, A.; Gauduel, Y.; Martin, J. L.; Antonetti, A. *Phys. Rev. Lett.* **1987**, *58*, 1559.
- 29) Bartczak, W. M.; Hilczer, M.; Kroh, J. *J. Phys. Chem.* **1987**, *91*, 3834.
- 30) Hirata, Y.; Mataga, N. *J. Phys. Chem.* **1991**, *95*, 9067.
- 31) Plonka, A. *Radiat. Phys. Chem.* **1992**, *39*, 17.
- 32) Kimura, Y.; Alfano, J. C.; Walhout, P. K.; Barbara, P. F. *J. Phys. Chem.* **1994**, *98*, 3450.
- 33) Pepin, C.; Goulet, T.; Houde, D.; Jay-Gerin, J.-P. *J. Phys. Chem.* **1994**, *98*, 7009.
- 34) Shi, X.; Long, F. H.; Lu, H.; Eienthal, K. B. *J. Phys. Chem.* **1996**, *100*, 11903.
- 35) Pépin, C.; Goulet, T.; Houde, D.; Jay-Gerin, J.-P. *J. Phys. Chem.* **1997**, *101*, 4351.
- 36) Turi, L.; Holpár, P.; Keszei, E. *J. Phys. Chem. A* **1997**, *101*, 5469.
- 37) Berg, M. A. *J. Chem. Phys.* **1999**, *110*, 8577.
- 38) Tewari, P. H.; Freeman, G. R. *J. Chem. Phys.* **1968**, *49*, 954.
- 39) Brown, B. J.; Barker, N. T.; Sangster, D. F. *J. Phys. Chem.* **1971**, *75*, 3639.
- 40) Dorfman, L. M.; Jou, F. Y.; Wageman *Ber. Bunsenges. Phys. Chem.* **1971**, *75*, 681.
- 41) Olinger, R.; Schindewolf, U. *Ber. Bunsenges. Phys. Chem.* **1971**, *75*, 693.
- 42) Stupak, C. M.; Tuttle, T. R., Jr.; Golden, S. *J. Phys. Chem.* **1984**, *88*, 3804.
- 43) Tuttle, T. R., Jr.; Golden, S.; Lwenje, S.; Stupak, C. *J. Phys. Chem.* **1984**, *88*, 3811.
- 44) Pekar, S. I. *J. Phys. USSR* **1946**, *10*, 341.
- 45) Jortner, J.; Rice, S. A.; Wilson, E. G.; Lepoutre, G. and Sienko, M. J., Ed.; W. A. Benjamin: New York, 1964, p. 264.
- 46) Jortner, J. *Radiation Res. Suppl.* **1964**, *4*, 24.
- 47) Jortner, J.; Stein, G., Ed.; *Radiation Chemistry of Aqueous Systems*. Weizmann Science Press of Israel: Jerusalem, 1968, p. 91.
- 48) Prezhdo, O. V.; Rossky, P. J. *J. Phys. Chem.* **1996**, *100*, 17094-17102.
- 49) Rossky, P. J.; Schnitker, J. *J. Phys. Chem.* **1988**, *92*, 4277-4285.
- 50) Schwartz, B. J.; Rossky, P. J. *J. Chem. Phys.* **1996**, *105*, 6997.
- 51) Turi, L.; Mosyak, A.; Rossky, P. J. *J. Chem. Phys.* **1997**, *107*, 1970.

- 52) Assel, M.; Laenen, R.; Laubereau, A. *J. Phys. Chem. A* **1998**, *102*, 2256.
- 53) Silva, C.; Walhout, P. K.; Reid, P. J.; Barbara, P. F. *J. Phys. Chem. A* **1998**, *102*, 5701.
- 54) Gottschall, W. C.; Hart, E. J. *J. Phys. Chem.* **1967**, *71*, 2102.
- 55) Vogelsang, R.; Schindewolf, U. *Ber. Bunsenges. Phys. Chem.* **1971**, *75*, 651.
- 56) Keene, J. P. *Radiation Res.* **1964**, *22*, 1.
- 57) Gordon, S.; Hart, E. J. *J. Am. Chem. Soc.* **1964**, *86*, 5343.
- 58) Fielden, E. M.; Hart, E. J. *Radiation Res.* **1967**, *32*, 564.
- 59) Olinger, R.; Schindewolf, U.; Gaathon, A.; Jortner, J. *Ber. Bunsenges. Phys. Chem.* **1971**, *75*, 690.
- 60) Gold, M.; Jolly, W. L. *Inorg. Chem.* **1962**, *1*, 818.
- 61) Burow, D. F.; Lagowski, J. J. *ACS Adv. in Chem.* **1965**, *50*, 125.
- 62) Golden, S.; Tuttle, T. R., Jr.; Lwenje, S. M. *J. Phys. Chem.* **1987**, *91*, 1360.
- 63) Kevan, L. ; Stein, G., Ed.; *Radiation Chemistry of Aqueous Systems*. Weizmann Science Press of Israel: Jerusalem, 1968, p. 21.
- 64) Kevan, L. *Acc. Chem. Res.* **1981**, *14*, 138-145.
- 65) Jeevarajan, A. S.; Fessenden, R. W. *J. Phys. Chem.* **1989**, *93*, 3511.

Recent Noteworthy Articles in the Area of Photochemistry and Photophysics

Editor's note: We are always looking for people to abstract recent exciting articles in photochemistry for the newsletter. Categories include, but are in no way limited to biochemical, organic, inorganic, and physical photochemistry. Please drop a note to William Jenks if you would like to participate.

Organic Photochemistry

Selected and abstracted by Michael P. Coleman and Mary K. Boyd, Department of Chemistry, Loyola University Chicago

1. "Intramolecular Electron Transfer of Diporphyrins Comprised of Electron-Deficient Porphyrin and Electron-Rich Porphyrin with Photocontrolled Isomerization" Tsuchiya, S., *J. Am. Chem. Soc.*, **1999**, *121*, 48-43.

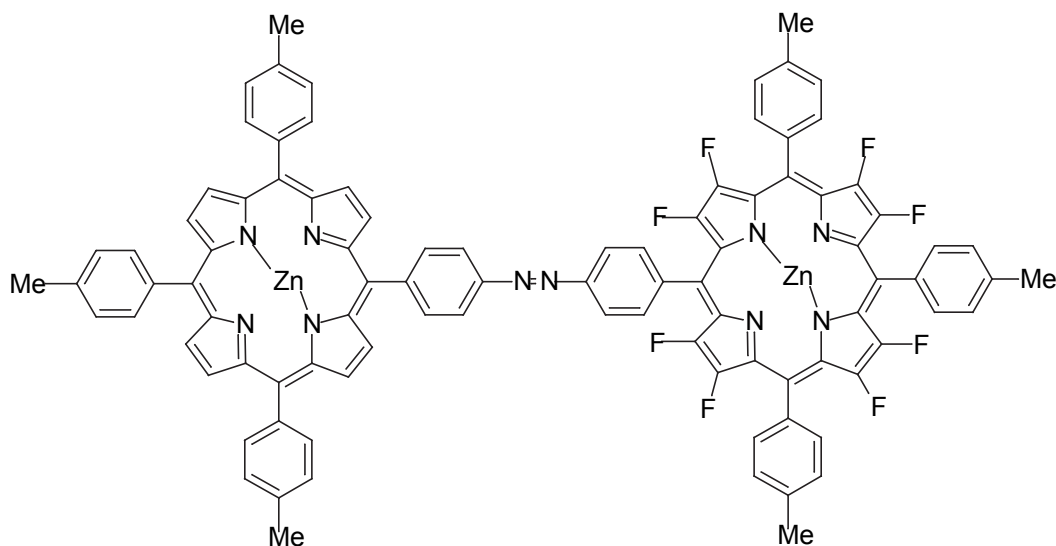

The structural versatility of porphyrin analogs as well as their potential electron transport capabilities makes them interesting targets for studies in molecular electronics. The use of azobenzene-linked diporphyrins and their Zn complexes were used in this study to demonstrate the photoresponsive properties of diporphyrins that contain one electron-deficient and one electron-rich unit. The hope is that through the use of an azobenzene linker between one electron-rich porphyrin and one electron-deficient porphyrin a photoinduced intramolecular electron transfer will be promoted. Substitutions at the β -position of one porphyrin with fluorine, in both Zn complexed and uncomplexed systems, produced a trans-cis photoisomerization when irradiated with light from a Xe lamp (10min) or high pressure Hg lamp (5min). The phenomenon was measured spectroscopically by changes in the Soret band and by the disappearance of a shoulder at 408nm in the UV spectrum of the diporphyrin, which corresponds to the (π - π^*) transition of the azobenzene linker in its trans form. This effect was proven fully reversible via a cis-trans

thermal recovery after one hour. It is interesting to add that in the Zn complexed systems a significant change in the fluorescence spectrum was observed after photoisomerization. The fluorescence intensity of the cis isomer was much smaller than that of the trans isomer, which suggests the observed fluorescence quenching of the cis isomer must be caused by an intramolecular electron transfer between the two rings.

2. "Laser Flash Photolysis and Computational Study of Singlet Phenylnitrene"

Gritsan, N.P.; Zhu, Z.; Hadad, C.M.; Platz, M.S. *J. Am. Chem. Soc.* **1999**, *121*, 1202-1207.

It is known that the photochemical decomposition of phenyl azide (PA) produces the open-shell singlet intermediate phenylnitrene (^1PN) but with little else known about the structural determination of these compounds. The direct detection of singlet phenylnitrene (^1PN) was recently announced with the activation parameters for cyclization of ^1PN to benzazirine (A) reported as $E_a = 6.2 \pm 0.4$ kcal/mol and $A = 10^{13.6 \pm 0.4} \text{s}^{-1}$. In this paper revised activation parameters for cyclization ($E_a = 5.6 \pm 0.3$ kcal/mol and $A = 10^{13.1 \pm 0.3} \text{s}^{-1}$) as well as the direct determination of (k_{ISC}), found to be $3.2 \pm 0.3 \times 10^6 \text{s}^{-1}$, are reported for the first time. These values are based on direct observation of the photochemical decomposition of phenyl azide. Laser flash photolysis of phenylazide (266nm, 35ps, 10mJ) in pentane at 233K produced intermediates with a strong, structured absorption band at 350nm and a weaker band at 540nm. Complete active space (CASSCF) quantum chemical calculations of the absorption spectra of ^1PN were undertaken and gave good agreement with spectroscopic data.

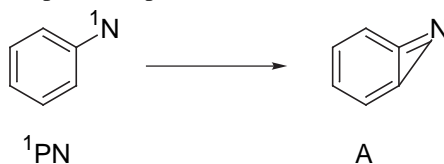

3. "Photochemistry of *ortho*-Phenoxymethyl-Substituted Aryl Azides: A Novel Nitrene Rearrangement En Route to Isolable Iminoquinone Methides?" Bucher, G.; Korth, H.G. *Angew. Chem. Int. Ed.* **1999**, *38*, 212-214.

Triplet aryl nitrenes are produced via intersystem crossing (ISC) from singlet nitrene generated from aryl azide photolysis. This reaction is markedly enhanced at lower temperatures and, with the appropriate substitution pattern, the risk of intramolecular addition of singlet nitrene to a carbon-carbon double bond is severely hindered, thus efficient conversion to the triplet is possible. Such a phenomenon brings up the interesting possibility of their use in nitrene rearrangements. In this research, the irradiation of 2,6-bis(phenoxymethyl)-1-azido-benzene **1** at 320nm in acetonitrile at 10K exclusively produced the triplet aryl nitrene **2** that is photostable at that temperature. The compound was isolated in an Ar matrix at 10K and characterized with UV/Vis and IR spectroscopy, with strong bands in the absorption spectrum at 288, 296 and 398nm and a weak band that extends to 539nm, all indications that nitrene rearrangement did not occur. Temperature was found to be a critical factor based on repeat irradiations conducted in 2-methyl-tetrahydrofuran glass (77K), which produced only minute amounts of the target triplet aryl nitrene. Photolysis of the aryl azide in the presence of a secondary amine (diethylamine) did not produce the expected azepine. Spectroscopic data instead revealed the major product to be 6-*exo*-methylene-2-phenoxymethyl-cyclohexa-2,4,-diene-1-one-N,N-diethylhydrazone. The lack of evidence for a hydrazine intermediate from spectroscopic data led to the mechanistic assumption that the first excited state of the aryl nitrene did not insert into the N-H bond of diethyl amine. Instead it is postulated to undergo an intramolecular rearrangement to form an

oxonium ylide which would ring open to form an oxime, with a subsequent reaction with diethylamine followed by elimination of phenol to produce the surprisingly stable iminoquinone methide product **4**.

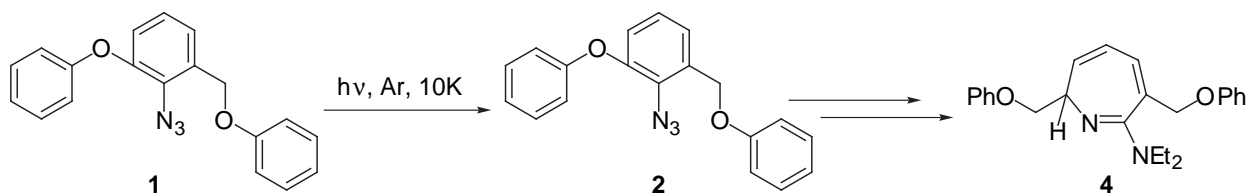

4. "Introducing Structural Diversity in Oligonucleotides via Photolabile, Convertible C5-Substituted Nucleotides" Kahl, J.D.; Greenberg, M.M. *J. Am. Chem. Soc.*, **1999**, *121*, 597-604.

Functional diversity within oligonucleotides has been the focus of increased attention due to recent interest in combinatorial strategies used to produce libraries of non-native nucleosides. This research describes a scheme in which *o*-nitrobenzyl protected alkyl amines and alkyl carboxylic acids are substituted on the C5 position within the nitrogenous base of uridine. Incorporating the nucleic acid within an oligonucleotide during solid-phase automated synthesis and then irradiating the oligonucleotide at 365 nm converts the modified, protected nucleosides into the subsequent free amine or carboxylic acid modified base. The result is oligomers that are widely diverse and contain strategically placed functionalities within the strand. The advantage is a modification system that can be applied *after* oligonucleotide synthesis without damage to the biopolymer. Deprotection efficiencies are reported as $\geq 94\%$ based upon isolated yields of oligomers 20 base-lengths long containing one modified nucleoside. The least efficient photo-conversions occurred in oligomers with modified nucleosides closer to the 3' end of the chain. The resulting modified oligonucleotides are interesting substrates for bioconjugate work. Oligonucleotide conjugates have been produced via PyBOP mediated on-column couplings as well as in solution-phase oligonucleotide/tripeptide couplings.

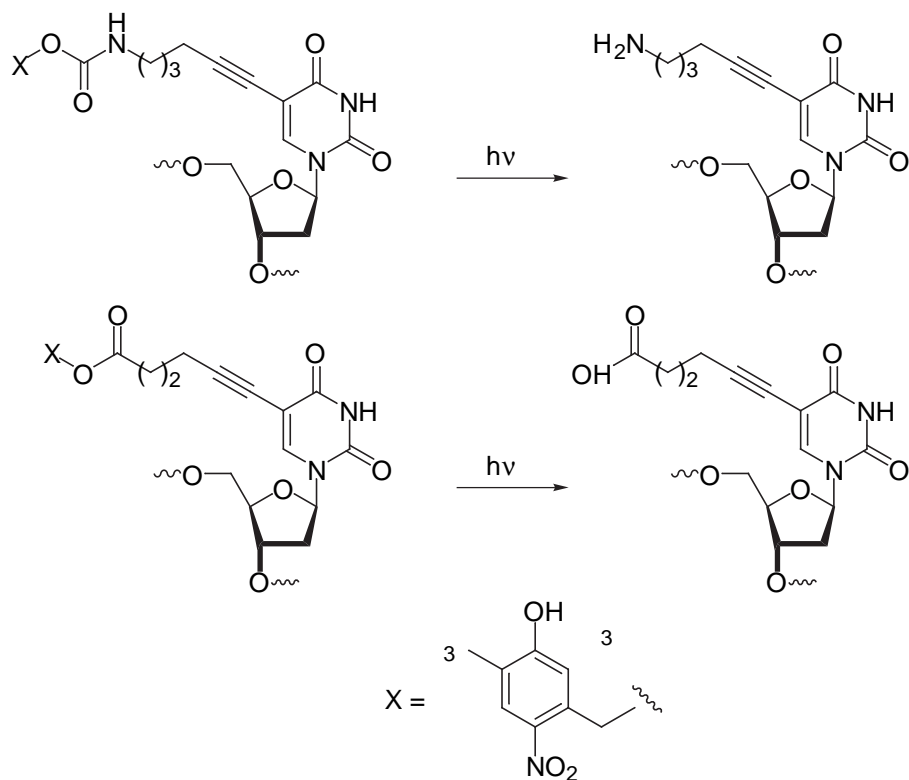

5. "Are Pyridinethiones Reliable Photochemical Oxyl-Radical Sources for Photobiological Studies? The Importance of Secondary Photolysis Products in the Guanine Oxidation of 2'-Deoxyguanosine and Cell-Free DNA" Adam, W.; Grimm, N.G.; Marquart, S.; Saha-Moller, C.R. *J. Am. Chem. Soc.*, **1999**, *121*, 1179-1185.

Photooxidation reagents used in DNA strand cleavage is an area of study that has evolved into its own unique discipline of chemistry. In this research a new class of photooxidants used as a source of oxyl radicals is introduced, pyridinethiones. The advantage of this source is a system that will chemically produce hydroxy radicals through the Fenton reaction without initiating undesirable redox chemistry that is commonly seen in γ radiolysis of water. The effectiveness of pyridinethiones in these reactions was initially observed for the photooxidative consumption of 2'-deoxyguanosine. The photooxidation of cell-free DNA was tested via a variety of pyridinethione derivatives with the general experimental assessment being made between those derivatives that produce hydroxyl radicals and alkoxy radicals. N-alkoxy and N-benzoyloxy substituted derivatives were found to be considerably less effective as photooxidants than N-hydroxy derivatives. In the case of the N-hydroxy derivatives, an N,N' dioxide dimer photoproduct was found to effectively inhibit the reaction and was produced exclusively by N-hydroxy derivatives. From this observance it was determined that hydroxy radicals were the main source of photoinduced DNA strand cleavage.

Spectroscopic and Photophysical Properties of Metal Alkylidyne

Lisa McElwee-White

Department of Chemistry, University of Florida, Gainesville, Florida 32611

Introduction

The luminescence and photochemical reactivity of metal alkylidyne complexes have prompted numerous studies of their photophysical properties. Early workers in this area suggested the possibility that their long-lived emissive excited states could facilitate photochemical conversions to useful products.^{1,2} Our interest in the photochemistry of these compounds was stimulated by the discovery that photolysis of $\text{Cp}\{\text{P}(\text{OR})_3\}(\text{CO})\text{Mo}\equiv\text{CR}'$ and $\text{Cp}\{\text{P}(\text{OR})_3\}(\text{CO})\text{W}\equiv\text{CR}'$ [$\text{R} = \text{alkyl, aryl}$; $\text{R}' = \text{alkyl}$] in CHCl_3 results in conversion of the carbyne ligands to organic products.³ Continuing investigations of the spectroscopic properties of metal alkylidynes bearing d^2 electron configurations have revealed common features in their absorption and emission spectra, leading to a coherent picture of the electronic structure of these complexes.

Group 6 Alkylidynes.

Luminescence of metal alkylidynes in room temperature solution was first reported by Bocarsly in 1985.¹ Complexes of the general type $\text{W}(\equiv\text{CPh})(\text{CO})_2\text{L}_2\text{X}$ where $\text{L}_2 = \text{TMEDA, bpy, dppe or py}_2$ and $\text{X} = \text{halide}$ were found to exhibit UV/visible spectra in which a strong band at approximately 254 nm was accompanied by a second strong absorption in the range of 325-360 nm ($\epsilon = 5500 - 17000$) and a much weaker band between 445-475 nm ($\epsilon = 350 - 1000$). The highest energy transition was assigned as $d \rightarrow \pi^*_{\text{CO}}$, based on its insensitivity to variations in L , X and the alkylidyne substituent, while the band at roughly 340 nm was assigned as $\pi \rightarrow \pi^*$ (alkylidyne-phenyl) based on its dramatic blue shift in $\text{W}(\equiv\text{C}^t\text{Bu})(\text{CO})_2(\text{TMEDA})\text{Cl}$. The lowest energy transition was described as a $d \rightarrow \pi^*$ (alkylidyne) MLCT transition by comparison to calculations on *trans*- $\text{Cr}(\equiv\text{CPh})(\text{CO})_4\text{Cl}$.⁴ Excitation into the low energy band ($\lambda = 450 - 500 \text{ nm}$) of the arylalkylidynes resulted in the observation of Stokes-shifted emission bands with λ_{max} at approximately 650 nm but no emission was observed from the alkylalkylidyne $\text{W}(\equiv\text{C}^t\text{Bu})(\text{CO})_2(\text{TMEDA})\text{Cl}$.² Emission lifetimes for the phenylalkylidynes ranged from 180 - 440 nsec. Quenching of the luminescent excited state by triplet energy transfer was demonstrated for $\text{W}(\equiv\text{CPh})(\text{CO})_2(\text{py})_2\text{Br}$ and electron transfer from the excited state of $\text{W}(\equiv\text{CPh})(\text{CO})_2(\text{TMEDA})\text{Cl}$ to MV^{2+} occurred with a quantum yield of 0.032.

Corroborating evidence for the electronic structure postulated for the $\text{W}(\equiv\text{CPh})(\text{CO})_2\text{L}_2\text{X}$ series was provided by a structural study of $\text{W}(\equiv\text{CPh})(\text{dmpe})_2\text{Br}$ and its one-electron oxidized counterpart $[\text{W}(\equiv\text{CPh})(\text{dmpe})_2\text{Br}][\text{PF}_6]$.⁵ The minimal structural changes upon oxidation were consistent with assignment of the HOMO as a non-bonding metal d orbital. A 9000 cm^{-1} blue shift of the lowest energy transition upon replacement of the phenyl group with *tert*-butyl allowed assignment of this band as $d \rightarrow \pi^*$ (alkylidyne), as in the $\text{W}(\equiv\text{CPh})(\text{CO})_2\text{L}_2\text{X}$ complexes. Additional evidence appeared in the vibronic structure of the low temperature emission band, in which the 1150 cm^{-1} progression was interpreted as an excited state weakening of the 1360 cm^{-1} $\nu(\text{W}\equiv\text{C})$ observed in $\text{W}(\equiv\text{CPh})(\text{CO})_4\text{Br}$.

Our observation of organic photooxidation products from $\text{Cp}\{\text{P}(\text{OR})_3\}(\text{CO})\text{Mo}\equiv\text{CR}'$ and

$\text{Cp}\{\text{P}(\text{OR})_3\}(\text{CO})\text{W}\equiv\text{CR}'$ [R = alkyl, aryl; R' = alkyl]³ led us to undertake spectroscopic studies of $\text{Cp}\{\text{P}(\text{OMe})_3\}(\text{CO})\text{M}\equiv\text{CR}$ and $\text{Cp}\{\text{P}(\text{OMe})_3\}_2\text{M}\equiv\text{CR}$ [M = Mo, W] complexes.⁶ The UV/visible spectra of the arylalkylidynes $\text{Cp}\{\text{P}(\text{OMe})_3\}(\text{CO})\text{M}\equiv\text{CPh}$ exhibit a strong absorption band in the range of 320 - 335 nm ($\epsilon = 5000 - 13000$) and a much weaker low energy band ($\lambda_{\text{max}} = 470 - 500$ nm, $\epsilon = 50 - 200$). Based on the similarity of the spectra to those of the $\text{W}(\equiv\text{CPh})(\text{CO})_2\text{L}_2\text{X}$ series, the transitions were assigned as $\pi \rightarrow \pi^*$ (alkylidyne-phenyl) and $d \rightarrow \pi^*$ (alkylidyne) respectively. For the corresponding alkylalkylidynes (R = Me, cyclopropyl), the expected blue shifts of both transitions were indeed observed. Since the CHCl_3 solvent had served as the electron acceptor in the original photooxidation studies, a solvent dependence study of the absorption spectra was carried out in order to rule out CTTS bands in the absorption spectra. The low energy $d \rightarrow \pi^*$ (alkylidyne) MLCT transition was identified as the source of both the electron transfer quenching in CHCl_3 and emission in room temperature solution (*vide infra*).

The emission behavior of these $\text{CpL}_2\text{M}\equiv\text{CR}$ compounds exhibited a puzzling dependence on the nature of the two ancillary ligands L. For arylalkylidynes bearing one carbonyl and one phosphite, emission at approximately 700 nm could be observed in room temperature solution. The analogous compounds in which $\text{L}_2 = (\text{CO})_2$ or $[\text{P}(\text{OMe})_3]_2$ were not luminescent. Emission from the $\text{Cp}(\text{CO})[\text{P}(\text{OMe})_3]\text{M}\equiv\text{CR}$ complexes could be quenched by organic compounds whose triplet energies were less than 59 kcal/mol above the ground state.

Further information on the lowest excited state of the $\text{Cp}(\text{CO})[\text{P}(\text{OMe})_3]\text{M}\equiv\text{CR}$ complexes was obtained in a nanosecond laser flash photolysis study.⁷ Transient absorption difference spectra of $\text{Cp}(\text{CO})[\text{P}(\text{OMe})_3]\text{M}\equiv\text{CR}$ (M = Mo, W; R = Ph, 2-Np) exhibited broad bands with λ_{max} in the 440 - 460 nm range. The excited states were strongly absorbing in that region with $\Delta\epsilon$ determined to be $3000 \text{ M}^{-1}\text{cm}^{-1}$ for $\text{Cp}(\text{CO})[\text{P}(\text{OMe})_3]\text{W}\equiv\text{CPh}$. Excited state lifetimes derived from the transient absorption data were reasonable matches for the emission lifetimes (Table 1), allowing the transient absorptions to be assigned to the emissive state. Although substantial $d \rightarrow d$ character had been ascribed to the lowest excited states of $\text{Cp}(\text{CO})[\text{P}(\text{OMe})_3]\text{M}\equiv\text{CR}$ complexes based on the low molar absorptivities of the ground states and the frontier orbital compositions from Extended Hückel calculations, the strong transient absorptions of the excited states more closely resembled those of $d\pi(\text{M}) \rightarrow \pi^*$ (ligand) MLCT excited states in d^6 metal diimine complexes such as $[(\text{bpy})\text{Re}^{\text{I}}(\text{CO})_3(\text{py})]^+$.⁸

Table 1. Emission and Transient Absorption Data for $\text{Cp}(\text{CO})\{\text{P}(\text{OMe})_3\}\text{M}\equiv\text{C-R}^{\text{a,b}}$

M	R	298 K ^c			77 K ^d	
		$\lambda_{\text{max}} / \text{nm}$ (kK)	$\tau_{\text{em}} / \text{ns}$	$\tau_{\text{TA}} / \text{ns}$	$\lambda_{\text{max}} / \text{nm}$ (kK)	$\tau_{\text{em}} / \mu\text{s}$
W	Ph	747 (13.4) ^e	141 ^e	129	741 (13.5)	3.2
Mo	Ph	^f	^f	49	787 (12.7)	8.3
W	o-Tol	745 (13.4) ^e	170 ^e	---	735 (13.6)	3.6
W	2-Np	> 780 (<12.7)	66	60	---	---

^a λ_{max} = emission maximum; τ_{em} = emission lifetime; τ_{TA} = transient absorption decay lifetime. ^b Estimated errors: $\tau_{\text{em}}, \pm 5\%$; $\tau_{\text{TA}}, \pm 5\%$. ^c Argon degassed THF solutions. ^d Argon degassed 2-MeTHF glasses. ^e Reported in ref. 6. ^f Too weak for accurate determination.

We have also examined electron transfer from the excited state of $\text{Cp}\{\text{P}(\text{OPh})_3\}(\text{CO})\text{W}\equiv\text{CPh}$ to a series of pyridinium and nitroaromatic electron acceptors.⁹ Laser flash photolysis demonstrated that quenching of the transient absorption by each acceptor is accompanied by the appearance of a long-lived transient that is characteristic of the corresponding radical ion product, thereby confirming that quenching occurs via electron transfer. The radical cation of the alkylidyne could not be observed but is expected to be highly reactive based on prior photooxidation chemistry of related complexes.^{3,6} Stern-Volmer quenching studies were carried out with a series of five pyridinium ion and four nitroaromatic electron acceptors. The reduction potentials of the electron acceptors¹⁰ and corresponding Stern-Volmer quenching rate constants (k_q) are compiled in Table 2. As expected for an electron transfer mechanism, k_q increased as the reduction potential of the electron acceptor became less negative.

Table 2. Rate Constants for Electron Transfer Quenching of $\text{Cp}\{\text{P}(\text{OPh})_3\}(\text{CO})\text{W}\equiv\text{CPh}$ ^a

Quencher	$E_{1/2} / \text{V}^b$	$k_q / 10^9 \text{ M}^{-1}\text{s}^{-1}$
N,N'-dimethyl-4,4'-bipyridinium	-0.45 ^c	5.1
N-methyl-4,4'-bipyridinium	-0.54 ^c	4.7
p-dinitrobenzene	-0.69 ^d	9.6
o-dinitrobenzene	-0.81 ^d	5.4
p-nitrobenzaldehyde	-0.86 ^d	4.9
m-dinitrobenzene	-0.90 ^d	4.9
N-methyl isonicotinamide cation	-0.93 ^c	3.2
nitrobenzene	-1.15 ^d	0.53
N-methyl pyridinium	-1.33 ^{c,e}	0.15
N-methyl 4- <i>tert</i> -butylpyridinium	-1.45 ^{c,e}	0.028

^aEstimated error in $E_{1/2}$ values is ± 0.05 V for reversible waves and ± 0.1 V for irreversible waves. Estimated error in rate constants is $\pm 10\%$. ^bV vs. SCE reference. ^cFrom ref. 9 ^dFrom ref. 10. ^eCathodic peak potential for irreversible wave.

Closely related are the cationic carbynes $[(\text{Me}_3\text{TACN})(\text{CO})_2\text{M}\equiv\text{CPh}]^+$ where $\text{M} = \text{Mo}, \text{W}$.¹¹ Despite the change from an ancillary Cp to the purely σ -donating Me_3TACN ligand, the electronic spectra of the complexes exhibit the same intense absorptions in the 320 - 340 nm region and weak absorptions in the range of 400 - 500 nm. For this system the high energy band generally assigned to a $\pi \rightarrow \pi^*$ transition in other Group 6 alkylidynes is instead described as MLCT although the relevant orbitals are not specified. Substantial $d \rightarrow d$ character in the low

energy band is invoked as the reason for its low extinction coefficient as was previously done for the $\text{Cp}(\text{CO})[\text{P}(\text{OMe})_3]\text{W}\equiv\text{CPh}$ series.⁷ $[(\text{Me}_3\text{TACN})(\text{CO})_2\text{W}\equiv\text{CPh}]^+$ exhibits emission at 630 nm in acetonitrile solution. The red shift of the emission and its lifetime of 83 ns were ascribed to triplet character in the excited state. The shorter emission lifetime with respect to complexes in the $\text{Cp}(\text{CO})[\text{P}(\text{OMe})_3]\text{W}\equiv\text{CPh}$ and $\text{W}(\equiv\text{CPh})(\text{CO})_2\text{L}_2\text{X}$ series was attributed to electronic differences caused by the neutral macrocyclic ligand. Related cationic carbyne complexes bearing the HCpy_3 and Ppy_3 ligands have also been prepared for spectroscopic study.¹² However, changing from the purely σ -donating Me_3TACN ligand to the π -acidic HCpy_3 and Ppy_3 ligands resulted in no significant changes in the spectroscopic properties of the complexes.

Further conjugation of the alkylidyne moiety into a metallabutadiyne was explored by Hopkins.⁵ The $\text{W}(\equiv\text{CH})(\text{dmpe})_2(\text{CCR})$ ($\text{R} = \text{H}, \text{SiMe}_3, \text{Ph}$) complexes **1a-c** were prepared in order to test the effects of extending the π -system on their electronic structure. The lowest excited states of **1a-c** exhibited weak absorptions ($\epsilon \cong 400$) in the 450 - 470 nm range, as expected on the basis of prior work on other d^2 alkylidynes. These bands were given the standard $d \rightarrow \pi^*$ assignment. However, red shifts from the equivalent absorptions in their $\text{W}(\equiv\text{CH})(\text{dmpe})_2\text{X}$ ($\text{X} = \text{Cl}, \text{I}, \text{n-Bu}$) analogues where $\lambda_{\text{max}} = 403 - 426$ nm, were cited as evidence of conjugation through the metallabutadiyne system.

All of the complexes discussed to this point have had a d^2 electron configuration, assuming the alkylidyne ligand bears a 3^- charge when assigning the d-electron count. The d^0 alkylidynes have generally not been the subject of spectroscopic study, since complexes of the type $(\text{Me}_3\text{CO})_3\text{W}\equiv\text{CR}$ tend to be colorless or pale yellow and fail to luminesce. However, additional conjugation in these systems can render their spectroscopic properties more interesting. For example the d^0 dialkylidyne complexes $(\text{RO})_3\text{W}\equiv\text{C}-\text{C}\equiv\text{W}(\text{OR})_3$ ($\text{R} = \text{CMe}_3, \text{OCMe}_2\text{CF}_3, \text{OCMe}_2\text{Et}$) exhibit highly complex absorption spectra with six or seven discrete bands between 240 and 470 nm.¹³ In contrast, the mononuclear complex $(\text{Me}_3\text{CO})_3\text{W}\equiv\text{CCMe}_3$ gives rise to three absorptions at 253, 297 and 330 nm. The authors did not assign bands in the dialkylidyne spectra, citing difficulties due to threefold symmetry in the complexes but they did invoke the red shift in the lowest energy band of the dinuclear complexes as evidence of conjugation. Although the electron demand of the alkoxide ligands varied, the spectra of the three dialkylidyne complexes were virtually identical, suggesting that the electronic changes in the ligands affect the ground and excited states to a similar degree.

More extensive conjugation in d^0 alkylidynes was explored following preparation of the pyridylalkylidynes $[(\text{Me}_3\text{CO})_3\text{W}\equiv\text{C}(4\text{-NC}_5\text{H}_2\text{Me}_2)]_n$ (**2a**) and $[(\text{Me}_3\text{CO})_3\text{W}\equiv\text{C}(3\text{-NC}_5\text{H}_4)]_n$ (**2b**).¹⁴ On the basis of crystallographic studies, these compounds were determined to be polymeric in the solid state with the repeating units linked by W-N bonds. Although twisting in the polymer backbone precludes maximal π -overlap, the spectroscopic properties of these complexes are clearly consistent with conjugation in the π -system. Polymers **2a** and **2b** are luminescent both in the solid state and in room temperature solution (λ_{max} in the solid state for **2a**: 635 nm; for **2b**: 640 nm) in contrast to the analogous monomers $(\text{Me}_3\text{CO})_3\text{W}\equiv\text{CR}$ ($\text{R} = \text{alkyl}, \text{aryl}$). No emission can be detected from the monomers, a negative result in accord with the rarity of luminescence from compounds with lowest lying LMCT excited states.¹⁵ Emission bands

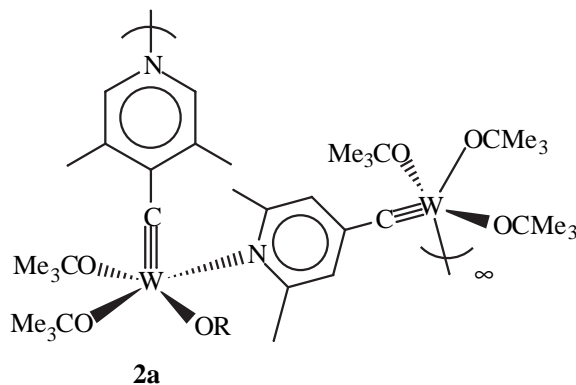
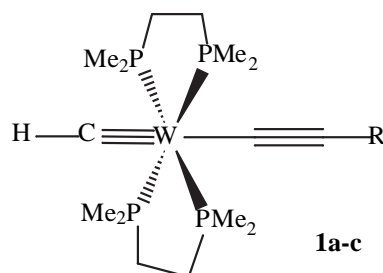

from **2a-b** are overlaid with a vibronic structural progression of approximately 1000 cm^{-1} spacing, which closely matches a Raman determination of $\nu(\text{W}\equiv\text{C})$.¹⁶ The spacing of these features is invoked as evidence that the electronic transitions arise from the $\text{W}\equiv\text{C}$ -py backbone.

Group 7 Alkylidyne.

Most of the spectroscopic studies of metal alkylidynes have featured complexes of Group 6 metals as described above. However, there have been a few recent reports of the photophysics of Group 7 complexes as well. The d^2 complexes $[\text{Re}(\equiv\text{C-Mes})(\text{pdpp})_2\text{Cl}]^+$ and $[\text{Re}(\equiv\text{C-Mes})\text{L}_2(\text{CO})(\text{H}_2\text{O})\text{Cl}]^+$ ($\text{L} = \text{PPh}_3, \text{P}(\text{C}_6\text{H}_5\text{-}p\text{-OMe})_3, \text{PMe}_2\text{Ph}$) exhibit strong absorptions in the range of 318 - 330 nm accompanied by weak bands in the range of 405-470 nm.¹⁷ The large extinction coefficients of the high energy absorptions are taken as evidence of charge transfer character with assignments of $d \rightarrow \pi^*$ (alkylidyne) or $d \rightarrow$ (phosphine) suggested. The less intense lower energy bands are assigned in the standard way as $d \rightarrow d_{\pi^*}$, where the substantial d character in the LUMO leads to weak absorption. These complexes are emissive in the solid state, in glasses and in room temperature solution, with the low-temperature spectra exhibiting vibronic progressions with spacings of approximately 1050 cm^{-1} that were assigned to $\nu(\text{Re}\equiv\text{C})$. Plots of $\ln k_{\text{nr}}$ vs. the emission energy were linear for these Re alkylidynes, consistent with the energy gap law for radiationless transitions.

These studies were later extended to a series of $[\text{Re}(\equiv\text{C-C}_6\text{H}_4\text{-}p\text{-X})(\text{pdpp})(\text{CO})_2\text{OTf}]^+$ complexes where $\text{X} = \text{OMe}, \text{Me}, \text{H}, \text{Cl}, \text{Br}, \text{CN}$.¹⁸ In contrast to the Group 6 complexes described above, in which the HOMO is a nonbonding metal d orbital,^{6,7} HF-SCF calculations on the model compound $[\text{Re}(\equiv\text{C-Ph})(\text{H}_2\text{PCH=CHPh})_2\text{Cl}]^+$ yielded a π ($\text{Re}\equiv\text{C-Ph}$) orbital as the HOMO. The weak low energy absorptions ($\lambda_{\text{max}} = 370 - 430$ nm) in the electronic spectra of these complexes are thus assigned as spin forbidden $\pi \rightarrow \pi^*$ ($\text{Re}\equiv\text{C-Ph}$) transitions. The more intense transitions in the 310 - 354 nm range are assigned as the spin allowed HOMO - LUMO excitations. These assignments are supported by the observation that varying the ancillary ligands has little effect on the energies of the transitions while significant effects are observed upon changing the p -substituent X in the benzylidyne ligand. Excitation into the bands from 300 - 350 nm induces emission in the range of 520 - 610 nm. A linear correlation between the emission energies and the Hammett σ parameters of the X groups provides further evidence that the phenyl ring is conjugated into the frontier orbitals. The authors make the point that changing this substituent allows the emission energy of the $[\text{Re}(\equiv\text{C-C}_6\text{H}_4\text{-}p\text{-X})(\text{pdpp})(\text{CO})_2\text{OTf}]^+$ complexes to be tuned.

Synthesis of $\text{Re}(\equiv\text{C-Mes})(\text{PPh}_3)(\text{H}_2\text{O})\text{X}_3$ ($\text{X} = \text{Cl}, \text{Br}$)¹⁹ allowed comparison of the spectral properties of these d^1 complexes to be compared to those of the more common d^2 species. Absorption spectra of the d^1 compounds are more complex, each exhibiting 5 - 6 bands in the range of 315 - 696 nm. Both complexes are emissive, with the luminescence red-shifted by approximately 30 - 40 nm with respect to the lowest energy absorption. The assignments of the transitions are based on literature discussion of d^2 W alkylidynes and are tentatively made as $d \rightarrow \pi^*$ (alkylidyne) with the standard comment that $d \rightarrow d$ character arising from strong metal d contribution to the LUMO lowers the extinction coefficients. All in all, the photophysical properties of these d^1 complexes strongly resemble those of the d^2 $[\text{Re}(\equiv\text{C-Mes})\text{L}_2(\text{CO})(\text{H}_2\text{O})\text{Cl}]^+$ alkylidynes.¹⁷

Group 8 Alkylidyne.

A pair of reports discuss the spectroscopic properties of Group 8 alkylidyne. An early paper on the photochemical addition of HCl to $\text{Os}(\equiv\text{C-Ph})(\text{PPh}_3)_2(\text{CO})\text{Cl}$ quotes $\lambda_{\text{max}} = 318$ ($\epsilon = 13500$) and 366 ($\epsilon = 4700$) nm for the Os alkylidyne.²⁰ Assignment of the bands as MLCT was made by comparison to related nitrosyl complexes. Continuation of the analogy led to postulation of a bent alkylidyne excited state, which would facilitate the observed protonation of the alkylidyne carbon by HCl.

Analysis of the spectra of the simple alkylidyne complex $(\text{NH}_3)_5\text{Os}\equiv\text{C-Ph}^{3+}$ is made easier by the C_{4v} local symmetry at the metal center and the non-interference of the ammine ligands in the excited states.²¹ This complex is another d^2 species with an intense band at 292 nm ($\epsilon = 14300$) and a lower intensity band at 462 nm ($\epsilon = 200$). The higher energy transition was assigned as $\pi \rightarrow \pi^*$ on the basis of an intensity decrease upon replacement of the aryl substituent by an alkyl moiety. Excitation of CH_3CN solutions of $(\text{NH}_3)_5\text{Os}\equiv\text{C-Ph}^{3+}$ at 462 nm resulted in detection of emission centered at 632 nm. Triplet character in the excited state was demonstrated by quenching with the anthracene triplet. The excited state could also be quenched by a series of substituted pyridines. The correlation of the quenching rate constant with the pK_a of the pyridinium led to a proposed proton transfer mechanism for the quenching.

Conclusion

Despite variation in the metal and the ancillary ligands, the electronic spectra of d^2 and d^1 alkylidyne complexes tend to follow a general pattern. The spectra are dominated by a pair of bands: one high intensity absorption at approximately 310 - 350 nm accompanied by a second band at lower energy (400 - 550 nm) with a much lower extinction coefficient. Although detailed assignments differ depending on orbital ordering in the specific complex, most follow the pattern established for the d^2 W(IV) alkylidyne. The high energy absorption is generally assigned as $\pi \rightarrow \pi^*$ (alkylidyne) while the lower energy transition is ascribed to $d \rightarrow \pi^*$ (alkylidyne) with the low extinction coefficient variously attributed to $d \rightarrow d$ character in the transition or to spin-forbiddenness. Alkylidyne complexes tend exhibit Stokes-shifted luminescence with substantial emission lifetimes, even in room temperature solution, and they are likely to exhibit vibronic structure from $\nu(\text{M}\equiv\text{C})$ in their low temperature emission spectra. Emission from the complexes has been shown to be quenched by electron transfer or triplet energy transfer. These photophysical properties have resulted in considerable interest in the excited states of metal alkylidyne.

List of Abbreviations:

- bpy = 2,2'-bipyridine
- Cp = η^5 -cyclopentadienyl
- dmpe = 1,2-bis(dimethylphosphino)ethane
- dppe = 1,2-bis(diphenylphosphino)ethane
- HCpy₃ = tris(2-pyridyl)methane
- Mes = 2,4,6-trimethylphenyl
- Me₃TACN = 1,4,7-trimethyl-1,4,7-triazacyclononane
- MV²⁺ = methyl viologen
- Np = naphthyl

pdpp = *o*-phenylenebis(diphenylphosphine)
Ppy₃ = tris(2-pyridyl)phosphine
py = pyridine
TMEDA = tetramethylethylenediamine

References

- 1) Bocarsly, A. B.; Cameron, R. E.; Rubin, H. D.; McDermott, G. A.; Wolff, C. R.; Mayr, A. *Inorg. Chem.* **1985**, *24*, 3976-3978.
- 2) Bocarsly, A. B.; Cameron, R. E.; Mayr, A.; McDermott, G. A. in *Photophysics and Photochemistry of Coordination Compounds*, Yersin, H. and Vogler, A., Ed.; Springer-Verlag: Berlin, 1987, pp 213-216.
- 3) McElwee-White, L. *Synlett* **1996**, 806-814.
- 4) Kostic, N. M.; Fenske, R. F. *Organometallics* **1982**, *1*, 489-496.
- 5) Manna, J.; Gilbert, T. M.; Dallinger, R. F.; Geib, S. J.; Hopkins, M. D. *J. Am. Chem. Soc.* **1992**, *114*, 5870-5872.
- 6) Carter, J. D.; Kingsbury, K. B.; Wilde, A.; Schoch, T. K.; Leep, C. J.; Pham, E. K.; McElwee-White, L. *J. Am. Chem. Soc.* **1991**, *113*, 2947-2954.
- 7) Schoch, T. K.; Main, A. D.; Burton, R. D.; Lucia, L. A.; Robinson, E. A.; Schanze, K. S.; McElwee-White, L. *Inorg. Chem.* **1996**, *35*, 7769-7775.
- 8) Lucia, L. A.; Schanze, K. S. *Inorg. Chim. Acta* **1994**, *225*, 41-49.
- 9) Cavalheiro, C. C. S.; Torraca, K. E.; Schanze, K. S.; McElwee-White, L. *Inorg. Chem.* , in press.
- 10) Bock, C. R.; Connor, J. A.; Gutierrez, A. R.; Meyer, T. J.; Whitten, D. G.; Sullivan, B. P.; Nagle, J. K. *J. Am. Chem. Soc.* **1979**, *101*, 4815-4824.
- 11) Lee, F. W.; Chan, M. C. W.; Cheung, K. K.; Che, C. M. *J. Organomet. Chem.* **1998**, *552*, 255-263.
- 12) Lee, F. W.; Chan, M. C. W.; Cheung, K. K.; Che, C. M. *J. Organomet. Chem.* **1998**, *563*, 191-200.
- 13) Gilbert, T. M.; Rogers, R. D. *J. Organomet. Chem.* **1991**, *421*, C1-C5.
- 14) Pollagi, T. P.; Geib, S. J.; Hopkins, M. D. *J. Am. Chem. Soc.* **1994**, *116*, 6051-6052.
- 15) Paulson, S.; P., S. B.; Caspar, J. V. *J. Am. Chem. Soc.* **1992**, *114*, 6905-6906.
- 16) Manna, J.; Kuk, R. J.; Dallinger, R. F.; Hopkins, M. D. *J. Am. Chem. Soc.* **1994**, *116*, 9793-9794.
- 17) Xue, W. M.; Wang, Y.; Mak, T. C. W.; Che, C. M. *J. Chem. Soc.-Dalton Trans.* **1996**, 2827-2834.
- 18) Xue, W. M.; Wang, Y.; Chan, M. C. W.; Su, Z. M.; Cheung, K. K.; Che, C. M. *Organometallics* **1998**, *17*, 1946-1955.
- 19) Xue, W. M.; Chan, M. C. W.; Mak, T. C. W.; Che, C. M. *Inorg. Chem.* **1997**, *36*, 6437-6439.
- 20) Vogler, A.; Kisslinger, J.; Roper, W. R. *Z.Naturforsch.(B)* **1983**, *38*, 1506-1509.
- 21) Trammell, S.; Sullivan, B. P.; Hodges, L. M.; Harman, W. D.; Smith, S. R.; Thorp, H. H. *Inorg. Chem.* **1995**, *34*, 2791-2792.

Zeolite as a Spectroscopic Matrix

S. Uppili, P. Lakshminarasimhan and V. Ramamurthy*
Department of Chemistry, Tulane University, New Orleans, LA 70118

Photochemistry of triplets of organic molecules is a well-developed field.¹ Despite its maturity encountering systems whose photophysical behavior is not as expected is not uncommon. For example one might face a frustrating situation of being unable to observe phosphorescence from molecules of interest. Photochemists are also interested in characterizing the reactive intermediates that might arise in a photochemical reaction. True to their name these are intermediates and have a fleeting existence. There are two approaches to get a snapshot of these intermediates: (a) 'run with them and watch quickly' i.e., employ sophisticated time resolved laser spectroscopy or (b) 'tame the beast' i.e., make them loose their agility and prolong their lifetime. Our approach has been the latter. In recent years zeolites have been shown to be very useful matrices for generating, stabilizing and observing reactive species such as triplets, radical cations, radicals and carbocations. Results from our laboratory are highlighted below to impress upon the readers the potential of zeolite as a matrix to observe species of interest to photochemists. This article is neither critical nor exhaustive.

Triplets

Phosphorescence emission from organic molecules has been known since the last century.² Kasha and Lewis identified the triplet state as being responsible for the phosphorescence emission that is different from the short lived fluorescence.³ The importance of spin-orbit coupling in this process was quickly established by McClure, Kasha and McGlynn.⁴ Although very early reports of phosphorescence from dye molecules used a solid gel as the matrix, low temperature organic solvent glasses have been the primary choice for observation of phosphorescence from organic molecules.⁵ While organic glasses are well accepted media, they pose limitations such as requiring the experiments be carried out at liquid nitrogen temperature and incorporation of only small amounts of heavy atom solvents before an organic glass becomes opaque. In the last two decades alternate matrices (silica gel, alumina, sucrose, chalk, paper, polymers, micelles, and cyclodextrins) have been explored to record phosphorescence.^{6,7,8} In a number of these media phosphorescence even at room temperature has been observed. Occasionally heavy cation salts (eg., thallium, silver and lead salts) are incorporated to enhance the emission process. However, studies have been mostly restricted to aromatic compounds. We believe that zeolite is a powerful matrix to observe phosphorescence from organic molecules, even from those that do not phosphoresce under normal conditions.^{9,10} The potential of this technique is shown with three examples, aromatics, polyenes and azo compounds. Of the three sets of molecules, olefins and azo compounds rarely phosphoresce. Zeolites¹¹ are inexpensive, readily available,¹² and are capable of including a wide variety of organic molecules. Cations of interest can be easily exchanged into the commercially available Na⁺ forms of zeolites. Recording emission from these solid samples is just as easy from glassy matrix.

As shown in Figure 1, the emission spectrum of naphthalene is profoundly affected by inclusion in cation exchanged zeolite X. For low mass cations such as Li⁺ and Na⁺, the emission spectra show the typical naphthalene fluorescence. However, with increasing mass of the cation (e.g., Rb⁺ and Cs⁺) there is a dramatic decrease in fluorescence intensity and a simultaneous appearance of a new vibronically structured low energy emission that is

readily identified as the phosphorescence of naphthalene. This effect is found to be general. Intense phosphorescence is observed for a wide range of different organic guests such as anthracene, acenaphthene, phenanthrene, chrysene, fluoranthene, pyrene, and 1,2,3,6,7,8-hexahydroxyrene when included in Ti^+ -exchanged faujasites. Fused aromatics, with too large a diameter to fit through the 8-A windows of the X- and Y-type zeolites (e.g., coronene and triphenylene) do not show any phosphorescence when included within a zeolite. The observed emission spectrum in these cases closely resembles that for the crystalline guest with no evidence of heavy-atom perturbation.

The unique feature of this method is that we were able to observe phosphorescence from systems, which commonly fail to show this emission in organic glassy matrices even when they are subjected to heavy atom effect. Olefinic systems that under normal conditions do not show phosphorescence emit from their triplet states when included in Ti^+ -exchanged zeolites.

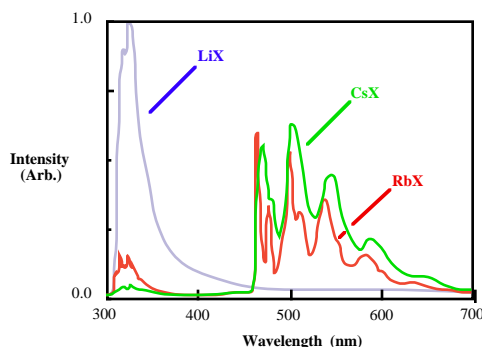

Figure 1: Emission spectra of naphthalene included within cation exchanged X zeolite at 77°K . Note the relative intensities of fluorescence and phosphorescence vary with the cation.

Excitation of *trans*-stilbene included in Ti^+ X and in Ti^+ ZSM-5 emits phosphorescence and fluorescence both at room temperature and at 77 K (Figure 2). The triplet emission maximum for stilbene measured within zeolites agrees well with the literature reports. The ability to record phosphorescence from stilbenes even at 298 K is significant as only very weak phosphorescence from *trans*-stilbene and several substituted *trans*-stilbenes have been recorded at 77 K in organic glass containing ethyl iodide as the heavy atom perturber.¹³ Even the singlet to triplet transition is easily seen in the excitation spectrum.

All-*trans*- α,ω -diphenylpolyenes exhibit very low intersystem crossing efficiencies and efficient fluorescence. We have succeeded in recording phosphorescence of these α,ω -diphenylpolyenes by including them in Ti^+ -exchanged zeolites. Figure 3 shows the observed phosphorescence of the α,ω -diphenylpolyenes included in Ti^+ X. The singlet-triplet energy gaps ($\Delta T_1 \rightarrow S_0$) obtained from the observed zero-zero lines are in excellent agreement with literature predictions.¹⁴

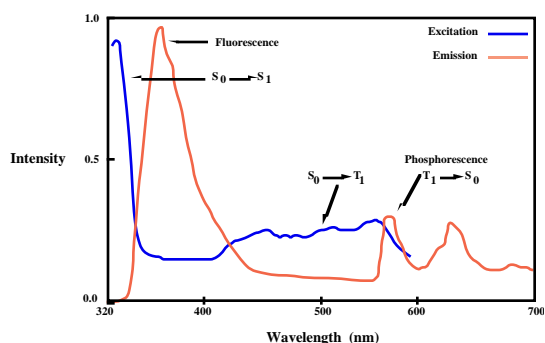

Figure 2: Emission spectrum of *trans*-stilbene included within TI+ ZSM-5 at 77° K. The excitation spectrum consists of the S_0 to T_1 transition.

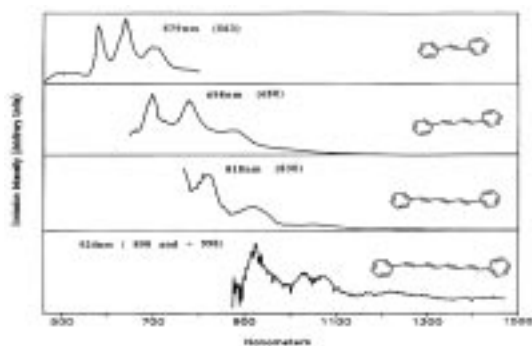

Figure 3: Phosphorescence spectra of all *trans*- α,ω -diphenylpolyenes included within TI+ ZSM-5 at 77° K.

The remarkable ability of zeolites to turn on phosphorescence is related to the spin orbit coupling parameter of the cations Cs^+ , Tl^+ and Pb^+ . It should be noted that just grinding the cation salt with organic molecules does not result in phosphorescence. Zeolite structure favors intimate interaction between cations and the included organic molecules. One can view the zeolite structure as an expanded crystal lattice of a cation salt. While in a powdered cation salt only the cations at the surface interact with an organic molecule, within a zeolite almost every cation is able to interact with the organic molecule.

The above observations demonstrate the ‘power’ of a zeolite as a new and versatile medium for ‘turning on’ the external heavy-atom perturbation of organic molecules in which intersystem crossing (ISC) occurs between $\pi\pi^*$ states. The rules for ISC, proposed by El Sayed suggest that heavy atom effect should be observable even in systems in which ISC occurs between the singlet and triplet states of $n\pi^*$ character (Figure 4).¹⁵ Preliminary studies suggest that this is possible. The two systems we have examined in this context are alkanones and azo compounds both of which have been established to undergo ISC from $n\pi^*$ singlet to pure $n\pi^*$ triplet states (no other states lie between them).

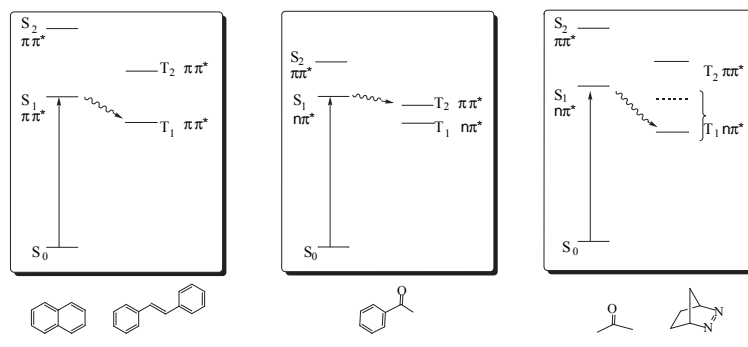

Figure 4: Possible scenarios for intersystem crossing between S_1 to T_1 .

Alkanones show both fluorescence and phosphorescence. In spite of the $n\pi^*$ character of both S_1 and T_1 the small energy gap is believed to favor ISC between these states. Examination of the emission characteristics of a few alkanones showed that the ratio of phosphorescence to fluorescence is higher in Tl^+ Y than in Na^+ Y (Figure 5). This observation indicated that a zeolite could influence the ISC between an $n\pi^*$ singlet and an $n\pi^*$ triplet. Results obtained with the azo compounds support the above conclusion. Numerous studies on azo compounds have established that they possess very poor ISC and do not show phosphorescence at 77K even in the presence of a heavy atom perturber. There is a single report of phosphorescence of azo compounds.¹⁶ The lack of ISC has been attributed to the presence of a large energy gap (>15 kcal/mole) and to the $n\pi^*$ character of the excited states involved in ISC. A number of azo compounds that are reported to show no phosphorescence in organic glass surprisingly showed phosphorescence within a Tl^+ Y zeolite. One such example is provided in Figure 6 and the details will be published shortly.

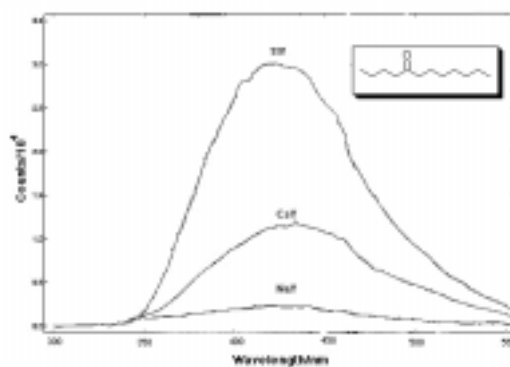

Figure 5: Phosphorescence spectra of 5-dodecanone included within Na Y, Cs Y and Tl Y. Emission recorded at 77°K. Note the enhancement in phosphorescence intensity with the heavier cation.

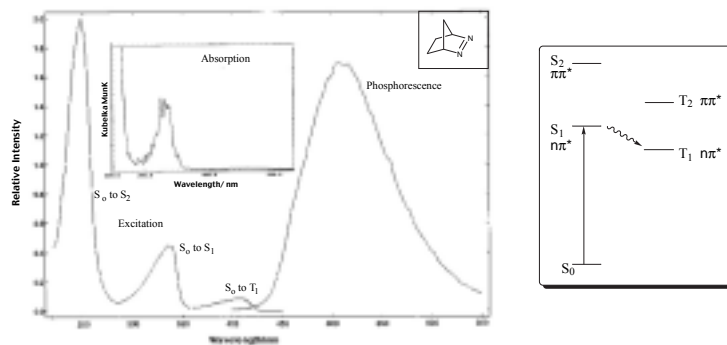

Figure 6: Emission and excitation spectra of diazo-(2,3)-bicycloheptane included within Tl Y, recorded at 77°K. Insert shows the diffuse reflectance absorption spectrum. The emission on the right is assigned to be phosphorescence. The longest wavelength band in the excitation spectrum is believed to be S_0 to T_1 transition.

We have identified Tl^+ and Pb^{2+} exchanged X, Y and ZSM-5 zeolites as ideal matrices to observe phosphorescence from most organic molecules. These heavy cation exchanged zeolites can be easily prepared by repetitive exchange from commercially available Na^+ X and Y and Na^+ ZSM-5 zeolites (Zeolyst).¹² Use of a ZSM-5 sample with high aluminum content (Si to Al ratio in the range 25 to 100) is advisable. For the cation exchange, a known amount (10 gms) of the Na^+ zeolite and a 10% w/v aqueous solution of the cation nitrate (e.g., thallium nitrate) (50 mL) was refluxed for 12 hrs. The zeolite was filtered, washed with excess water and dried. The above refluxing, washing and drying processes were repeated three times. The final sample was dried and kept for use.

We have adopted two methods to include an organic molecule into a zeolite. The loading level was maintained near 1 organic molecule per 50 supercages of X and Y zeolites. A typical procedure is as follows: The zeolite (200 mg) was dried in an oven at $\sim 500^\circ C$ for about 10 hrs prior to use. The dry zeolite, was quickly cooled to room temperature (within 5 mts under dry conditions) and added to a dry hexane solution containing the organic compound (~ 1 mg) of interest. The hexane-zeolite slurry was stirred for about six hours, filtered, washed with hexane (profusely) and air-dried. The sample thus prepared was generally not completely dry and contained unknown amounts of water. When a 'dry' zeolite sample was needed the above prepared sample was dried by degassing on a vacuum line ($\sim 10^{-4}$ mm) with slight heating ($\sim 85^\circ C$) for 8-10 hours. A cylindrical quartz tube (an ESR tube) was usually used to pack the sample. When we used vacuum dried sample all operations were done within a dry-box and the tube was sealed with a parafilm. All operations were done under normal laboratory conditions for the 'wet' sample. The cylindrical ESR tubes containing the zeolite sample was placed in a quartz Dewar (provided with most fluorimeters) and cooled for low temperature studies or used as such for room temperature measurements. Although the zeolite-organic powder was opaque no problems were encountered in recording the emission spectra. An appropriate filter was used to protect the detector from the reflected excitation beam of light. When the sample was packed in a square cell (0.1 mm pathlength) it was placed at an angle in the normal sample holder.

In the second method, the organic molecule was included into the zeolite simply by grinding (agate pestle) the dry zeolite with the organic compound in an agate mortar. The sample was allowed to equilibrate for about 6 hrs prior to use. In this method no solvent was used during the inclusion of an organic compound into the zeolite. Emissions observed from the samples prepared by the hexane slurry and grinding methods were very similar.

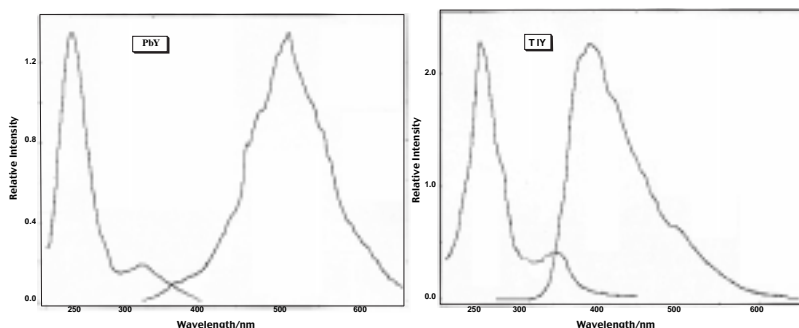

Figure 7: The emission and excitation spectra of Pb^{2+} Y and Tl^{+} Y without any guests. The emissions are weak and have been amplified in the Figure. These emissions will be near the base line in all the spectra shown in Figures 1-3 and 5.

It is important to note that only molecules that are smaller than the entrance aperture of zeolite supercages ($\sim 8.5\text{\AA}$) or channels of ZSM-5 (5.6\AA) can be subjected to heavy cation effect within a zeolite. One should also use Na^{+} exchanged X and Y zeolites (without binder) for heavy cation exchange.¹⁷ Commercial zeolites can occasionally be acidic and should be avoided. The acidity can be checked by a color test reported in the literature.¹⁸ The zeolite should always be activated (in an air oven at 500°C) prior to use. Since Tl^{+} and Pb^{2+} exchanged X and Y zeolites themselves show a weak emission (Figure 7) control experiments to eliminate the host zeolite emission are necessary.

Radical Cations

Radical cations play an important role in photoinduced electron transfer chemistry.¹⁹ Although spectral characterization of radical ions by time resolved laser spectroscopy is possible characterization by ESR requires sufficiently long lived radical ions. This is generally achieved by generating the radical ions within a solvent matrix (inert freon matrix) at low temperatures. Even in this matrix they have a relatively short lifetime (seconds). Silica gel, silica-alumina, and vycor glass have been explored as possible media to stabilize radical cations. During the last decade zeolites have emerged as a possible alternative to freon matrix to stabilize radical cations.²⁰ In this matrix radical cations have extended lifetimes (from hours to months). Several approaches have been made to generate radical cations within a zeolite: Trifunac and Thomas have demonstrated the use of radiolysis (γ -rays, X-rays and fast electrons).^{20,21} Another approach used quite extensively by Johnston, Scaiano and Thomas is laser photolysis.^{21,22} Though the radical cations generated by these approaches have a longer lifetime than that in solution, they do not have lifetimes of the order of days. We serendipitously came across a phenomenon in which the radical ions generated spontaneously within a ZSM zeolite have lifetimes of the order of months.²³ This phenomenon has since been shown to be widely prevalent by several groups (Roth, Garcia and Thomas).^{24,25} While the generation of radical cations within ZSM-5 zeolites has won unanimous approval by workers, disagreement exists on the mechanism by which the radical cations are generated within a zeolite.^{25,26} Observations of Roth, Garcia, Thomas and ours suggest that a photochemist should consider using zeolites as media to generate, stabilize and characterize radical cations of interest.

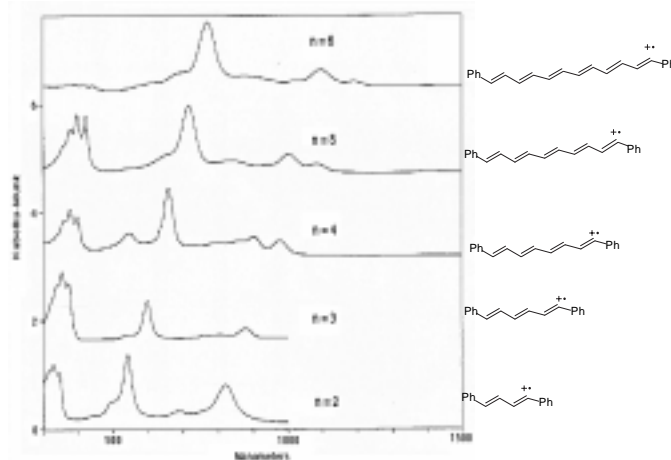

Figure 8: Diffuse reflectance spectra of α,ω -diphenylpolyenes included within Na^+ ZSM-5. All spectra seen here correspond to the radical cations of the olefins.

When activated Na^+ ZSM-5 (Si/Al=22) was stirred with α,ω -diphenylpolyenes (trans-stilbene, diphenylbutadiene, diphenylhexatriene, diphenyloctatetraene, diphenyldecapentene, and diphenyldodecahexaene) in 2,2,4-trimethylpentane, the initially white zeolite and colorless to pale yellow olefins were transformed into highly colored solid complexes within few minutes. All the samples exhibited intense ESR signals with g values of 2.0028. Diffuse reflectance spectra of these powders (Figure 8) are identical to the spectra of the radical cations of α,ω -diphenylpolyenes reported in the literature.²⁷ Diffuse reflectance and ESR results favor the conclusion that the colored species formed upon inclusion of α,ω -diphenylpolyenes in Na^+ ZSM-5 are radical cations. The colored α,ω -diphenylpolyene radical cations generated in the channels of Na^+ ZSM-5 were found to be unusually stable; even after several weeks storage at ambient temperature in air, the colors persisted and the peak positions of the diffuse reflectance spectra remained unchanged. This is to be contrasted with their short lifetimes in solution (microseconds) and in solid matrices (seconds). The remarkable stability of these radical cations in Na^+ ZSM-5 derives from the tight fit of the rod-shaped molecules in the narrow zeolite channels; the π -orbitals are protected from external reagents by the phenyl rings which fit tightly in the channels at both ends of the radical.

We have been able to generate radical cations of thiophenes as well. When activated Na^+ ZSM-5 (Si/Al 22) was loaded with terthiophene a deep red-purple complex was obtained. Comparison of the diffuse reflectance spectrum of the above deep red purple complex with flash photolysis results where the terthiophene cation radical is generated as a transient in solution shows excellent agreement.²⁸ As expected for a simple cation radical, an EPR spectrum for the above complex was observed although no hyperfine structure was resolved. The results obtained for terthiophene included in Na-ZSM-5 are not unique. The same type of one electron oxidation reaction for bithiophene and quaterthiophene included in ZSM-5 was observed (Figure 9). The stability of the cation radicals, which exist only as reactive intermediates in solution, is much higher within the zeolite channels; we have stored samples of the terthiophene cation radicals for months without any significant degradation even in the presence of air and water. Generation of radical cations of thiaanthrene, biphenyl, *para*-propylanisole, dithianes, and disulfides has been reported in the literature.

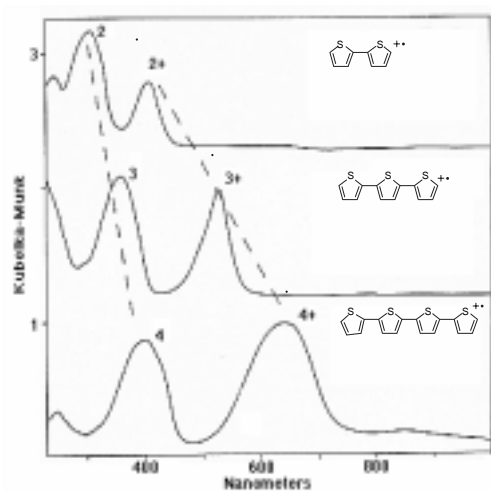

Figure 9: Radical cation formation of thiophene oligomers upon inclusion within Na⁺ ZSM-5. Diffuse reflectance spectra of radical cations recorded at room temperature.

The ability to generate and stabilize radical cations of polyenes has helped us to handle them as routine chemicals rather than as intermediates. For example we have recorded the emission spectra of radical cations of α,ω -diphenylpolyenes as one would record that of parent α,ω -diphenylpolyenes (Figure 10).

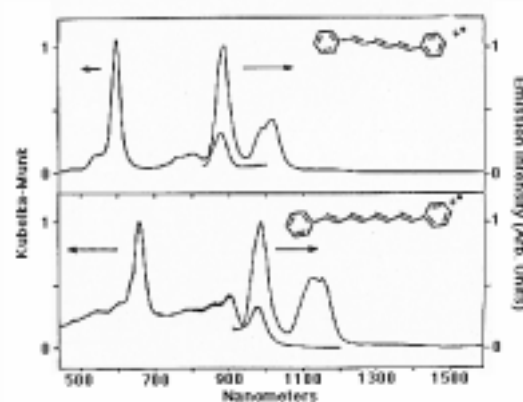

Figure 10: The emission spectra of the radical cations 1,6-diphenylhexatriene and 1,8-diphenyloctatetraene.

Spontaneous generation of radical cations by this method should take into account precautions such as Si/Al ratio (20-120) of the zeolite, molecular size and the oxidation potential (less than ~1.65 eV vs SCE) of the guest molecule. A typical procedure employed by us is described below: Weighed amounts of α,ω -polyenes and activated zeolite were stirred together in 20 mL of trimethylpentane for about 2 h. In a typical preparation 250 mg of the zeolite and 5 mg of the α,ω -polyene were stirred in 20 mL of the solvent. During this process, the zeolite developed color, which varied depending upon the olefin. The colored zeolite complexes were collected by filtration, washed with hexane several times to remove any material adsorbed on the external surface of the

crystallites, dried under nitrogen, and finally were thoroughly degassed (10^{-4} mm) in either Pyrex or quartz cells fitted with Teflon stopcocks. These cells were used for recording absorption, emission and ESR spectra.

Carbocations

One can generate and stabilize select carbocations within a zeolite. Although this method is less general than the ones described above for triplets and radical cations, it can be useful in certain cases. A few examples are highlighted below. The best choice of zeolite for generation of carbocations is Ca^{2+} Y. Zeolite Ca^{2+} Y is readily prepared from Na^+ Y by the cation exchange process described in an earlier section. Activation of the zeolite at 500°C in an air-oven results in the generation of two H^+ per supercage.²⁹ Such zeolites with controlled amounts of acid sites are useful in the generation of carbocations from alkenes. Long lived (months) carbocations from vinyl anisole, indene and 1,1-diphenyl ethylene have been generated in our laboratory by including them into activated Ca^{2+} Y. The cations generated in Na^+ Y have much shorter lifetime (msec) than in Ca^{2+} Y (months).³⁰ H^+ Y zeolites have been used by Garcia and co-workers to generate carbocations from alkenes.³¹ In our laboratory the preferred zeolite has been Ca^{2+} Y.³² Two examples are highlighted below.

When activated Ca Y was added to a solution of 4-vinylanisole in hexane, the zeolite developed a vibrant red-violet color. The diffuse reflectance spectrum of the solid zeolite sample presented in Figure 11 consists of two broad absorptions centered at 340 and 580 nm. We attribute the absorption at ~ 340 nm to the carbocation, 4-methoxy phenylethyl cation (see insert in Figure 11). The absorption spectrum for 4-methoxy phenylethyl cation has been reported in solution³³ and coincides remarkably well with the absorption maximum observed in zeolite. While 4-methoxy phenylethyl cation in solution lasts only for a few microseconds, in a zeolite it is stable for a few days.

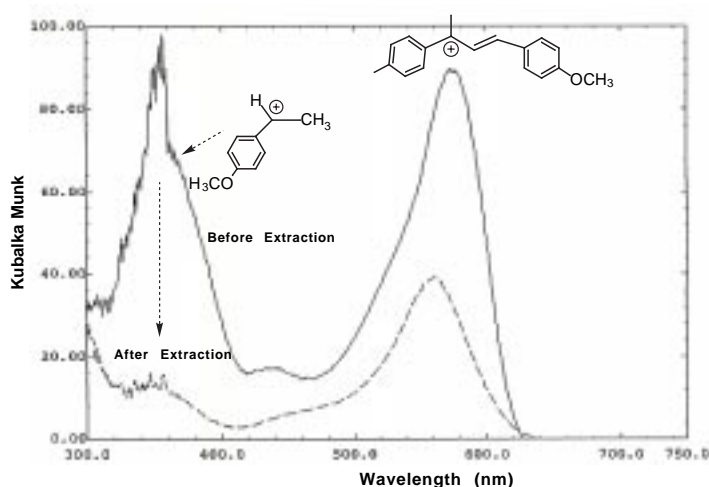

Figure 11: The diffuse reflectance spectra of the monomer and dimer cations of vinyl anisole included within Ca^{2+} Y. The structures of the cations are shown. The monomer cation can be selectively washed away leaving the dimer cation within the zeolite.

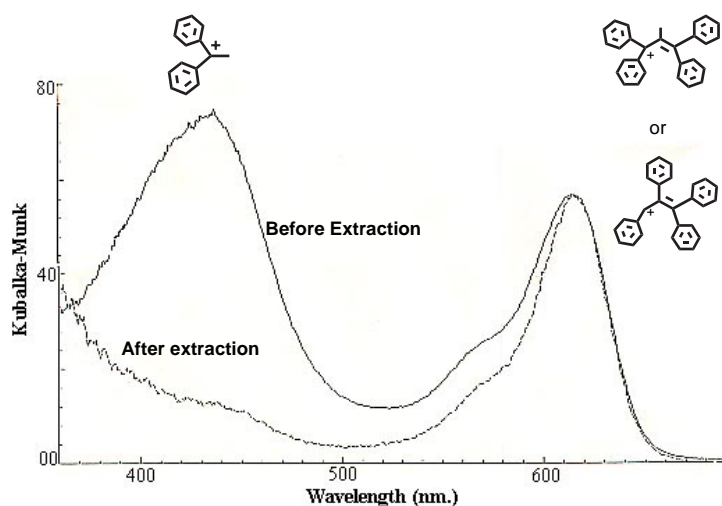

Figure 12: The diffuse reflectance spectra of the monomer and dimer cations of 1,1-diphenylethylene included within Ca^{2+} Y. The structures of the cations are shown. The monomer cation can be selectively washed away leaving the dimer cation within the zeolite. The exact structure of the dimer cations remains unresolved.

Behavior of diphenylethylene is similar to that of vinyl anisole. When activated Ca^{2+} Y was added to a hexane solution of 1,1-diphenylethylene, the zeolite-hexane slurry turned yellow and then green and remained green for several days. The diffuse reflectance spectra displayed in Figure 12 for 1,1-diphenyl ethylene- Ca^{2+} Y consist of two distinct maxima (one below 500 nm and the other above 600 nm). The absorption at 428 nm is attributed to diphenylmethyl cation (see insert in Figure 12). This is consistent with the literature assignment for such a species.³⁴ Once again the cation has a few microseconds lifetime in solution while within a zeolite it is stable for days. The cation generation is spontaneous. Simple stirring in hexane or grinding zeolite with the olefin results in stable carbocation which require no special precaution for stabilization.

The monomer cations of vinyl anisole and diphenylethylene were found to slowly dimerize to small amounts of dimeric cations which lasts for months. The structures of the dimeric cations are shown in Figures 11 and 12. The structure of the dimer cation from 1,1-diphenylethylene has not been conclusively established. What is important to note is that one can generate long-lived carbocations within a zeolite. The unusual ability to stabilize certain carbocations within zeolites has allowed us to handle them as 'normal' laboratory chemicals. For example we have been able to record emission from several of these cations. One such example is provided in Figure 13.

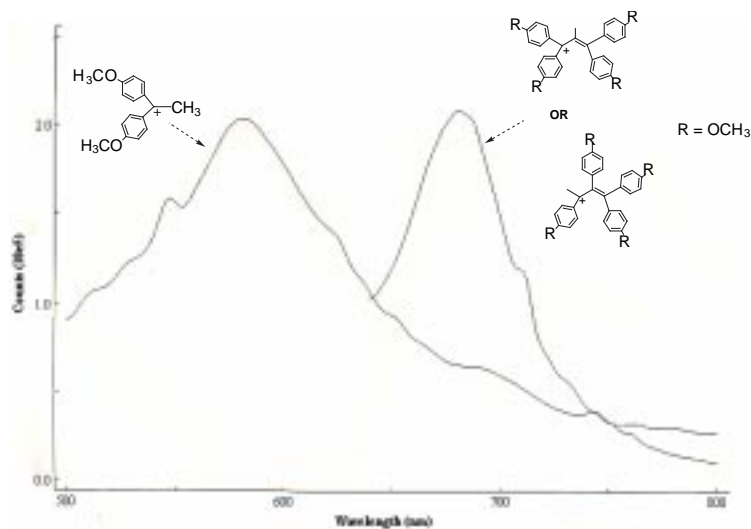

Figure 13: Fluorescence emission spectra of monomer and dimer carbocations of 1,1-dianisylethyelne included within Ca^{2+} Y recorded at room temperature. The structures of carbocations are shown. The exact structure of the dimer cations remains unresolved.

Summary

Zeolite is a porous highly interactive matrix. Zeolitic cations help to generate triplets from molecules that possess poor intersystem crossing efficiency. Certain zeolites act as electron acceptors and thus can spontaneously generate radical cations. Zeolites also act as proton donors and thus yield carbocations without any additional reagents. These reactive species, radical cations and carbocations, have long lifetime within a zeolite and thus lend themselves to be handled as 'regular' chemicals. In our laboratory zeolites have served as powerful matrices to monitor phosphorescence from molecules that do not phosphorescence under conventional conditions.^{35,36}

Acknowledgement: VR thanks Drs. D. F. Eaton, D. R. Corbin and J. V Caspar of the Du Pont Company for their wonderful contribution to the experimental and intellectual development of several zeolite projects that are being pursued at Tulane.

REFERENCES

1. N. J. Turro, *Modern Molecular Photochemistry*, University Science Books: Mill Valley, 1978.
2. E. Wiedemann, *Ann. Physik. (Leipzig)*, **1888**, 34, 446.
3. G. N. Lewis and M. Kasha, *J. Am. Chem. Soc.*, **1944**, 66, 2100.
4. (a) D. McClure, *J. Chem. Phys.*, 1949, 17, 905. (b) M. Kasha, *J. Chem. Phys.*, **1952**, 20, 71. (c) S. P. McGlynn, M. J. Reynolds, G. W. Daigre and N. D. Christodoyelas, *J. Chem. Phys.*, **1962**, 66, 2499.
5. S. L. Murov, I. Carmichael and G. L. Hug, '*Handbook of Photochemistry*', 2nd Ed., Dekker: New York, 1993, pp. 294-297.
6. R. J. Hurtubise, '*Phosphorimetry*', VCH: New York, 1990.
7. T. Vo-Dinh, '*Room Temperature Phosphorimetry for Chemical Analysis*', Wiley-Interscience: New York, 1984.

8. (a) R. Humphry-Baker, Y. Moroi and M. Gratzel, *M. Chem. Phys. Lett.*, **1978**, 58, 207. (b) K. Kalyanasundaram, F. Grieser and J. K. Thomas, *Chem. Phys. Lett.*, **1977**, 51, 501. (c) L. J. Cline Love, R. Weinberger and P. Yarmchuk, in *Surfactants in Solution, Vol. 2*, K. L. Mittal and B. Lindman, (Ed.) Plenum, New York, 1984, p. 1139.
9. V. Ramamurthy, J. V Caspar, E. W. Kuo, D. R. Corbin and D. F. Eaton, *J. Am. Chem. Soc.*, **1992**, 114, 3882.
10. (a) S. Uppili and V. Ramamurthy, unpublished results. (b) Studies on azo compounds are being pursued in collaboration with the groups of W. Adam and P. Engel. (c) Authors thank W. Adam and P. Engel for generous supply of azo compounds.
11. D. W. Breck, *Zeolite Molecular Sieves: Structure, Chemistry, and Use*, John Wiley and Sons, New York, 1974.
12. Zeolyst International is represented in USA by PQ Corporation, PO Box 840, Valley Forge, PA 19482-0840, Phone: 610-651-4552.
13. J. Saltiel, G. E. Khalil and K. S. Schanze, *Chem. Phys. Lett.* **1980**, 70, 233.
14. (a) G. Heinrich, G. Holzer, H. Blume and D. Schulte-Frohlinde, *D. Z. Naturforsch.* **1970**, 25b, 496. (b) D. F. Evans and J. N. Tucker, *J. Chem. Soc., Faraday Trans. II*, **1972**, 68, 174.
15. S. K. Lower and M. El Sayed, *Chem. Rev.*, **1966**, 66, 199.
16. W. Adam, G. Fragale, D. Klapstein, W. M. Nau and J. Wirz, *J. Am. Chem. Soc.*, **1995**, 117, 12578.
17. Note that Aldrich sells zeolites with and without binders. They are sold under the name molecular sieves.
18. K. J. Thomas and V. Ramamurthy, *Langmuir*, **1998**, 14, 6687.
19. M. A. Fox and M. Channon, *Photoinduced Electron Transfer*; Elsevier: Amsterdam, 1988.
20. D. W. Werst and A. D. Trifunac, *Acc. Chem. Res.*, **1998**, 31, 651.
21. J. K. Thomas, *Chem. Rev.*, **1993**, 93, 301.
22. (a) I. K. Lednev, N. Mathivanan and L. J. Johnston, *J. Phys. chem.*, **1994**, 98, 11444. (b) F. L. Cozens, R. Bogdanova, M. Régimbald, H. García, V. Marti and J. C. Scaiano, *J. Phys. Chem. B*, **1997**, 101, 6921.
23. (a) J. V. Caspar, V. Ramamurthy and D. R. Corbin, *J. Am. Chem. Soc.*, **1991**, 113, 600. (b) V. Ramamurthy, J. V. Caspar, and D. R. Corbin, *J. Am. Chem. Soc.*, **1991**, 113, 594.
24. (a) J. V. Folgado, H. Garcia, V. Marti and M. Espla, *Tetrahedron*, **1997**, 53, 4947. (b) A. Corma, V. Fornés, H. García, V. Martí and M. A. Miranda, *Chem. Mat.*, **1995**, 7, 2136. (c) P. S. Lakkaraju, D. Zhou and H. D. Roth, *Chem. Commun.*, **1996**, 2605. (d) P. S. Lakkaraju, J. Zhang, and H. D. Roth, *J. Chem. Soc., Perkin Trans. 2*, **1993**, 2319. (e) P. S. Lakkaraju, J. Zhang and H. D. Roth, *J. Phys. chem.*, **1994**, 98, 2722.
25. X. Lin, K.-K. Iu, J. K. Thomas, H. He and J. Klinowski, *J. Am. Chem. Soc.*, **1994**, 116, 11811.
26. V. Marti, L. Fernandez, V. Fornes, H. Garcia and D. D. Roth, *J. Chem. Soc. Perkin 2*, **1999**, 145.
27. (a) T. Shida and W. H. Hamill, *J. Phys. Chem.* **1966**, 44, 4372. (b) T. Shida and W. H. Hamill, *J. Phys. Chem.* **1966**, 44, 2375.
28. (a) J. C. Scaiano, C. Evans and J. T. Arnason, *J. Photochem. Photobio., B*: **1989**, 3, 411. (b) C. Evans and J. C. Scaiano, *J. Am. Chem. Soc.* **1990**, 112, 2694.
29. H. M. Kao, C. P. Grey, K. Pitchumani, P. H. Lakshminarasimhan and V. Ramamurthy, *J. Phys. Chem.*, **1998**, 102, 5627.
30. F. L. Cozens, M. O'Neill and N. P. Schepp, *J. Am. Chem. Soc.* **1997**, 119, 7583.
31. (a) M. L. Cano, A. Corma, V. Fornés, and H. García, *J. Phys. Chem.*, **1995**, 99, 4241. (b) H. Garcia, S. Garcia, J. P. Prieto and J. C. Scaiano, *J. Phys. Chem. B*, **1996**, 100, 18158. (c) V. Fornes, H. Garcia, V. Marti and L. Fernandez, *Tetrahedron*, **1998**, 54, 3827.

32. (a) K. Pitchumani and Ramamurthy, *J. Chem. Soc., Chem. Commun.* **1996**, 2763. (b) V. Jayathirtha Rao, N. Prevost, V. Ramamurthy, M. Kojima and L. J. Johnston, *J. Chem. Soc., Chem. Commun.* **1997**, 2209. (c) K. Pitchumani, P. H. Lakshminarasimhan, N. Prevost, D. R. Corbin and V. Ramamurthy, *J. C. S., Chem. Commun.*, **1997**, 181. (d) K. Pitchumani, A. Joy, N. Prevost and V. Ramamurthy, *J. C. S., Chem. Commun.*, **1997**, 127. (e) K. Pitchumani, P. H. Lakshminarasimhan, G. Turner, M. G. Bakker, and V. Ramamurthy, *V. Tetrahedron Letters*, **1997**, 371. (f) K. Pitchumani, D. R. Corbin, and V. Ramamurthy, *J. Am. Chem. Soc.* **1996**, *118*, 8152.
33. R. A. McClelland, C. Chan, F. Cozens, A. Modro and S. Steenken, *Angew. Chem. Int. Ed. Engl.*, 1991, **30**, 1337.
34. (a) R. A. McClelland, V. M. Kangasabapathy and S. Steenken, *S. J. Am. Chem. Soc.* **1988**, *110*, 6913. (b) A. Azarani, A. B. Berinstain, L. J. Johnston and S. Kazanis, *J. Photochem. A: Chem.* **1991**, *57*, 175.
35. (a) V. Ramamurthy, R. J. Robbins, K. J. Thomas and P. H. Lakshminarasimhan, in 'Organised Molecular Assemblies in the Solid State', J. K. Whitsell (ed.), John Wiley: Chichester, **1999**, pp. 63-140. (b) V. Ramamurthy, P. Lakshminarasimhan, C. P. Grey and L. J. Johnston, *J. Chem. Soc. Chem. Commun.*, **1998**, 2411-2424.
36. We would be happy to provide details on experimental procedures and assistance in the choice and procurement of zeolites. Contact: murthy@mailhost.tcs.tulane.edu.

The Pyrene Paradigm Ain't Worth Twenty Centimes!

or

A Lesson in Photochemical Incorrectness^{©,®}

Oscar E. Zimmerman and Richard G. Weiss

Department of Chemistry, Georgetown University, Washington, DC 20057-1227

For many years, pyrene has been a photophysical workhorse for probing local environmental properties, including structural, dynamic, and polar aspects of a medium.¹ For instance, I_1/I_3 fluorescence intensity ratios are used widely to estimate the polarities of environments where pyrene molecules reside,² fluorescence lifetimes assess whether specific quenchers are nearby, and the presence or absence of excimer emission and the dynamics of its appearance provide useful information about viscosity and diffusion.³



Although several other organic molecules supply some of the same information, few, if any, combine all of the convenient attributes of pyrene:

- (1) It is cheap and relatively easy to purify.
- (2) Its absorption spectrum extends well beyond 300 nm, so that Pyrex vessels may be used to excite it.
- (3) Its molar extinction coefficients at the peak maxima above 300 nm are $>10^4$ so that only a small amount is needed to attain an adequate optical density.
- (4) Its lowest excited singlet state is exceptionally long lived (> 300 ns in deoxygenated paraffinic solvents¹).
- (5) Its fluorescence quantum yield is high in most media.¹
- (6) Finally, the common perception (paradigm?) is that pyrene is photochemically inert under most experimental conditions.

Is the perception in (6) worth twenty centimes?^{4a} Our first inkling that the pyrene paradigm might be worth no more than a plugged nickel^{4b} came from an article by the Bordeaux photophysics group. They reported that irradiation of pyrene in a Shipolskii matrix of methane at 15 K resulted in efficient formation of 1-methylpyrene!!⁵

After considering the conditions of their reaction, we decided that the results were not pertinent to our research with pyrenyl compounds; we normally conduct our experiments at room temperature. However, since one of us was infected with $h\nu$ in Hammond's lab (like five of the six '38'ers[®]; the sixth is contaminated by recent associations), the Bordeaux results were placed in the "By George, that's great!" file for future consideration.

In addition, one of us had spent 3 months of a sabbatical at Bordeaux in the laboratory of Henri Bouas-Laurent during 1981. There, he learned several important lessons:

- (1) Weiss's French stinks worse than overripe Münster cheese!
- (2) Don't bring binoculars to the nude beaches at Arcachon.
- (3) Always leave snails in clean water for at least a day before calling them 'escargots'.
- (4) If one glass of red wine with lunch is good for your health, two glasses are four times as good.⁶ Somewhere around the fourth glass, 'goodness' becomes saturated according to the Bordeaux law of exponential decay.

It was the latter kernel of wisdom that made me wonder whether the Bordeaux photophysicists had cajoled their colleagues from the Institut de Oenologie, the prize of the Université (!), to let them 'analyze' a couple of bottles of Château Chimie before starting their seminal experiments. Certainly, we feel much better about our environment and our results when it is possible to practice 'green chemistry' by drinking ethanolic solvents; livers are biodegradable.

Sumptuous meals and stolen glimpses at Arcachon remained the principle memories of Bordeaux until we began searching for a convenient method that would attach photophysical probes only to *interior* positions of polymer films. Probes are usually attached covalently by copolymerization of a small amount of a probe-containing monomer and a simple monomer (like methyl methacrylate). However, when such polymers are cast into films, some of the probe groups reside at the polymer surfaces, also. The reports from Bordeaux suggested an approach to avoid this complication: "Rather than irradiate pyrene in a Shipolskii matrix at low temperatures, why not use a *preformed polymer film at room temperature?*" We learned later, after looking through the literature carefully, that the Bordeaux group had already made the 15K to room temperature jump.⁷

Our first efforts with the Pyrex-filtered output from a 450 W medium pressure Hg arc and a pyrene-doped polyethylene film were *successful*.⁸ After irradiation and exhaustive extraction of the film, its fluorescence spectrum appeared to be from 1-pyrenyl groups. However, on closer scrutiny, there was evidence for a second fluorescing species, also attached to the interior of the film (Figure 1).^{8b} Since that time, we have demonstrated that a wide range of polymer films can be modified with pyrenyl groups using similar protocols.⁹ Unfortunately, a second emission component is invariably present.

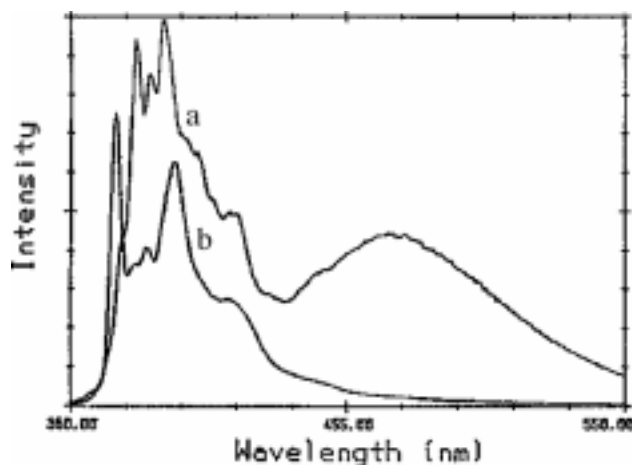

Figure 1. Fluorescence spectra (λ_{ex} 343 nm; in air) of (a) a pyrene-doped polyethylene film before irradiation and (b) the film in (a) after irradiation and exhaustive extraction (CHCl_3) of non-covalently attached pyrene molecules.

Again, had we read the literature coming from Bordeaux, we would have received a very strong hint about what the other species in our films might be. They had found at least *four* photoproducts when pyrene was irradiated in cyclohexane at 185 or 254 nm (Figure 2).¹⁰ Some of these are dihydropyrenyl species. Pyrene is fairly reactive even when irradiated in alcoholic or aqueous solutions, also, and forms at least two photoproducts.¹¹ In fact, there is no conclusive evidence that the singlet (from absorption of one high energy photon¹⁰) or triplet (from sequential absorption of two lower energy photons¹⁰) attachment mechanisms to polymers or low molecular-mass molecules in their liquid or solid phases produce exclusively pyrenyl derivatives. *Why not??* Those that are pyrenyl in nature may be attached at the 1-carbon as well as at other positions. *Why if the 1-position of pyrene is much more reactive than the others??*

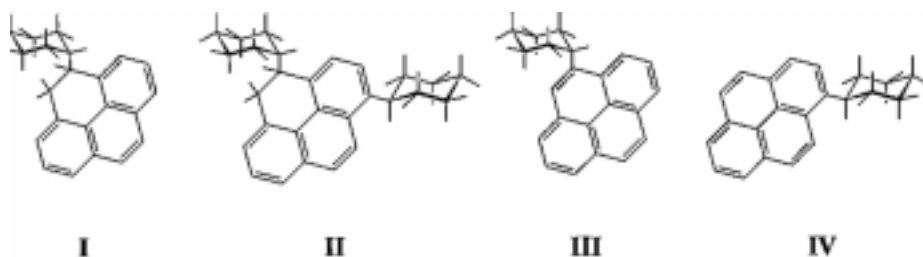

Figure 2. Structures of photoadducts from irradiations of pyrene in cyclohexane.¹⁰

In this laboratory, Neuter Nature (NN^{12}) is frequently very perverse, but it sometimes leaves devilishly clever clues, which the local devils seize upon. During one of our important scientific discussions,¹³ someone suggested that NN might be kinder if we were to design specific sites around a pyrene molecule from which a hydrogen can be abstracted and the resultant radical added to the 1-position of pyrene. Amazingly, ideas from RGW about how the editorial 'we' might construct such a site over a projected timeframe of 10 years stimulated an enormous number of simpler proposals from the normally quiet, younger members of the group.

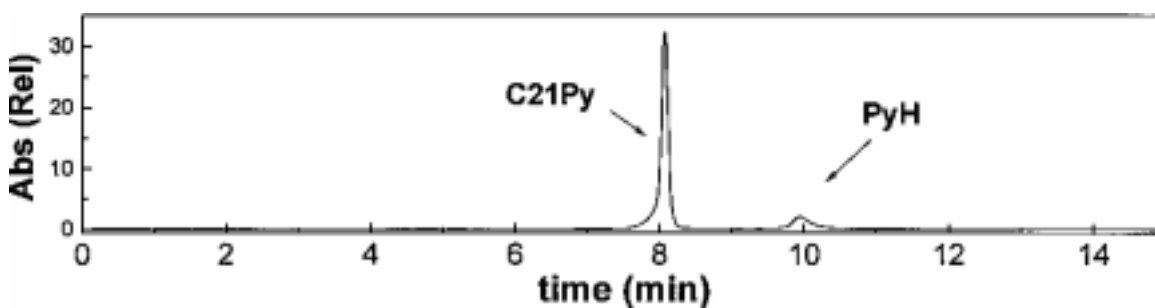

Figure 3. Gel permeation chromatogram (THF) of the degassed reaction mixture from irradiation of 5×10^{-6} M pyrene in solid *n*-heneicosane at room temperature. UV detection at 343 nm.

Of course, we opted eventually for the *simplest* idea, to irradiate pyrene in the solid phase of a long *n*-alkane. The initial attempt was in *n*-heneicosane ($C_{21}H_{44}$) using the Pyrex-filtered output of a medium pressure Hg lamp (as before). This alkane was selected for an excellent scientific reason—we had it in the lab. The pyrene concentration, 5×10^{-6} M, was chosen for an even better reason—why use a higher concentration and take a chance that the irradiation period might interfere with a Redskins football game on the tube?

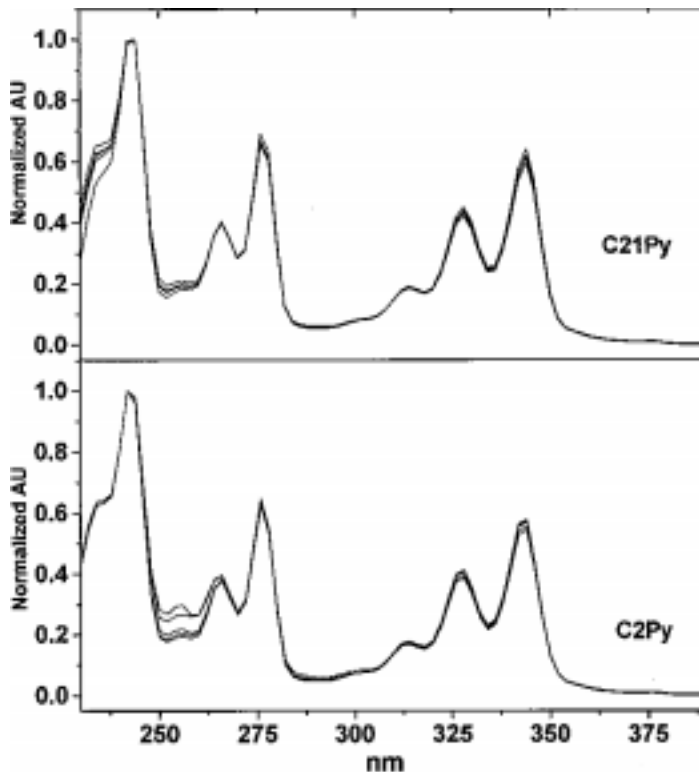

Figure 4. UV absorption spectra of the **C21Py** peak from the chromatogram in Figure 3 and of 1-ethylpyrene (**C2Py**) eluted on the same column. In both cases, spectra were recorded at various times during peak elution to check for homogeneity.

The well-crafted experiment was successful! A series of analyses indicated that most of the pyrene had been attached to molecules of *n*-heneicosane (Figure 3). Furthermore, the attachment appeared to be cleanly at the 1-position of pyrene. UV/vis absorption (Figure 4) and fluorescence spectra (Figure 5) of the isolated photoproduct, **C21Py**, are very similar to that of 1-ethylpyrene. Surprisingly, the unreacted pyrene after irradiation was *not* pure. Does this mean that there is a second reaction competing with attachment *or* that we don't know how to purify pyrene? In this case, the answer seems to be the former.

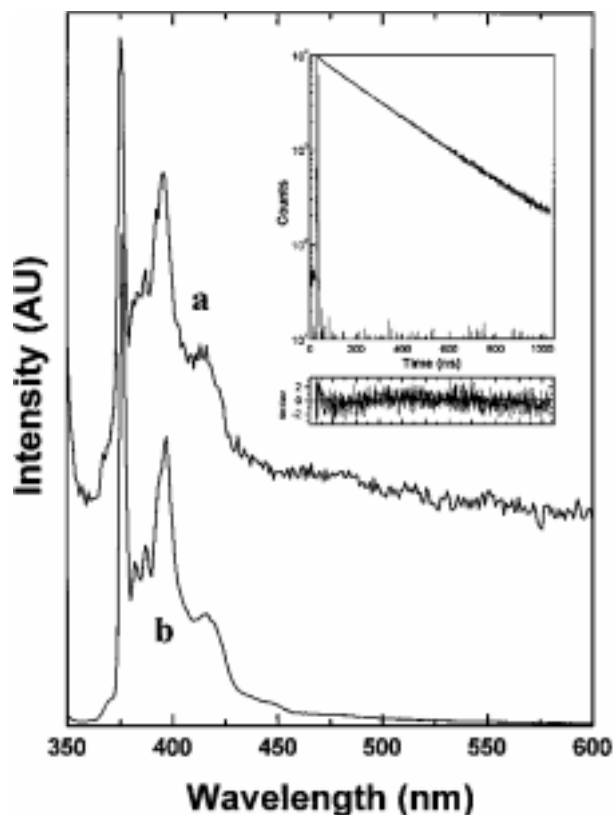

Figure 5. Fluorescence spectra (λ_{ex} 343 nm; hexane) of isolated **C21Py** (a) and 1-ethylpyrene (b). The inset is for the time-correlated single photon decay of the fluorescence from **C21Py** in hexane; see text for details.

Note also that there is an enormous component of excimer-like emission in the solid phase of *n*-heneicosane before irradiation even at the very low pyrene concentration (Figure 6a). Given the nature of the solvent matrix, this emission must come from ground-state aggregates. In the liquid phase of the same solution ($T > 45$ °C), there is no discernible excimer emission. Apparently, the pyrene molecules aggregate in small units as the solidification of the solution occurs. Were the aggregates large or shaped to prohibit contact between individual pyrene and *n*-heneicosane molecules, the conversion of pyrene would have been limited.

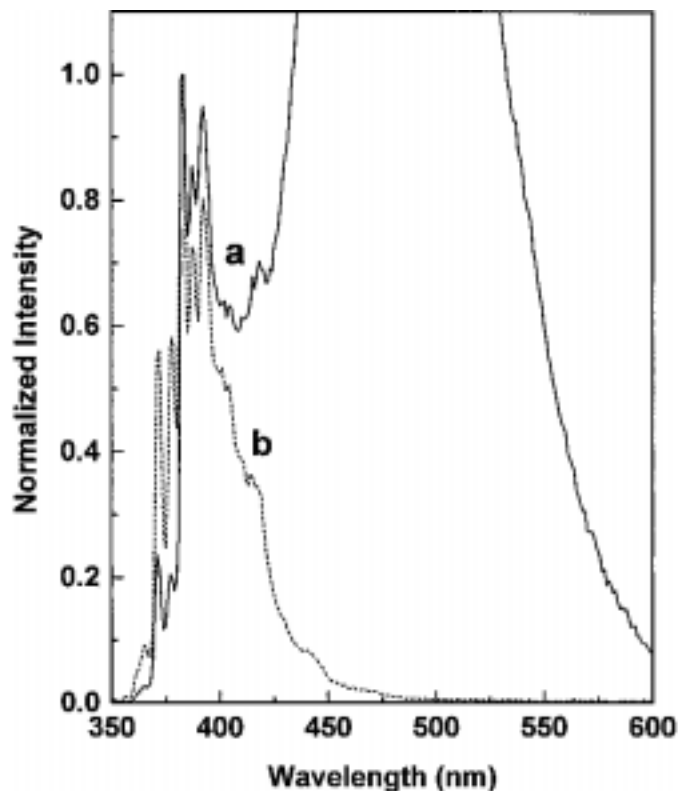

Figure 6. Fluorescence spectra (λ_{ex} 343 nm) of degassed 5×10^{-6} M pyrene in solid *n*-heneicosane at room temperature (a; solid) and at 50 °C (b; liquid).

Since the amount of **C21Py** was insufficient for NMR analyses, the position of attachment on the heneicosane chain was (and still is) unknown. We believe that it is at or near a chain end (i.e., the 1- or 2-carbon) based on serious scientific arguments. As such, they are outside the scope of this article.¹⁴ However, the photoproduct could be isolated in sufficient quantities for static emission and time-correlated single-photon counting experiments. In degassed hexane solution, the decays could be fit reasonably well to a single exponential decay function (inset of Figure 5) with $\tau = 249$ ns (λ_{ex} 343 nm; λ_{em} 376 nm).

Based on the information in Figure 5, we asked, “What happens when a sample is irradiated in its *liquid state* for the same period as in the solid?” The answer from NN was “uma bagunça.” Okay, who cares that we have no idea why liquid *n*-heneicosane and several other liquid *n*-alkanes produce messy photoproduct mixtures or that the other *n*-alkanes in their solid phases do not yield a ‘clean’ photoadduct? The more important question is, “*Why does NN speak Portuguese when everyone knows that the language of science is English and the language of pyrene is apparently French?*”

We were undeterred. We decided to increase the concentration of pyrene to 10^{-3} M in *solid n*-heneicosane, irradiate, and obtain a large amount of photoproduct. Not quite.... Apparently, larger aggregates are present in the higher concentration solid sample! Either the larger aggregates lead to enhanced photophysical quenching or only the small fraction of pyrene molecules at the surface of an aggregate can react. Regardless, NN said “nada” again.

Yes, we can attach pyrene to other *n*-alkanes rather efficiently provided they are in their solid phases....but not as cleanly as in *n*-heneicosane!! Yes, we believe we will be able to make relatively large quantities of 1-

alkylpyrenes in this way...with a little help from our (analytical) friends. Yes, we realize that pyrene, the wonderful photophysical probe, has its potential drawbacks. Each bottle of it, like the great wines of Bordeaux, should have a warning label: "May be contaminated with NN. Use at your own risk." In spite of that, pyrene is still a great photophysical probe. But beware.

So, where are we now? Far from sunny Bordeaux, and the pyrene paradigm is dying at an escargot's pace. We have a method for producing large amounts of probes *based on pyrene* in a wide variety of substrates....but the probe groups are not only 1-pyrenyl. We have a method to attach pyrene to *n*-alkanes....but we can't use it at high concentrations. We have discovered that pyrene is a francophilic probe....but we ain't French!

A potential solution to our problem, the use of French photons *de (Neutre) Nature* at Arcachon, will be tested. A proposal to NSF for those 'experiments' is in preparation. We ask the reviewers to treat our proposal kindly. However, even if it is not approved, my group and I will be stoic about the vagaries of NN and our dumb, unappreciative peer group; we will whine in the Bordeaux style.

Acknowledgments. We sincerely thank the Bordeaux group, especially Michel Lamotte and René Lapouyade, for several very helpful discussions and invaluable advice.

It may be unWeiss to mention that the National Science Foundation and the Petroleum Research Fund (administered by the American Chemical Society) funded this research.

☺ The authors dedicate this article to the old photochemists born in 1938 and honored at the ACS National Meeting in Boston during 1998. They deserve no worse. The question is whether they deserve anything better?

☺ A slightly different version of this research will be submitted for publication in *J. Phys. Chem., Part C*.

References

- ¹ See for instance: (a) Birks, J. B. *Photophysics of Aromatic Molecules*; Wiley: London, 1970. (b) Thulstrup, E. W.; Michl, J. *Elementary Polarization Spectroscopy*; VHS: New York, 1989. (c) Gordon, M.; Ware, W. R. (Eds) *The Exciplex*; Academic Press: New York, 1975.
- ² (a) Kalyanasundaram, K.; Thomas, J. K. *J. Am. Chem. Soc.* **1977**, *99*, 2039. (b) Dong, D. C.; Winnik, M. A. *Photochem. Photobiol.* **1982**, *35*, 17.
- ³ (a) Zachariasse, K. A.; Kühnle, W.; Weller, A. *Chem. Phys. Lett.* **1980**, *73*, 6. (b) Zachariasse, K. A.; Duveneck, G.; Busse, R. *J. Am. Chem. Soc.* **1984**, *106*, 1045.
- ⁴ Currency conversion information: (a) A French paradigm. (b) Ca. cinco centavos (Brazilian or Argentinian), but only on days when the IMF is in town.
- ⁵ Lamotte, M.; Jousot-Dubien, J.; Lapouyade, R.; Pereyre, J. in *Photophysics and Photochemistry above 6 eV*; Lahmani, F., Ed.; Elsevier: Amsterdam, 1985; 577.
- ⁶ I absolve Henri of any responsibility for the degradation of my liver and eyes caused by sampling the local delights.
- ⁷ (a) Lamotte, M.; Lapouyade, R.; Pereyre, J.; Jousot-Dubien, J. *C.R. Acad. Sc., Paris, Serie C*, **1980**, *211*, 290. (b) Lamotte, M.; Lapouyade, R.; Pereyre, J.; Jousot-Dubien, J. *Chem. Comm.* **1980**, 725. (c) Jousot-Dubien, J.; Lamotte, M.; Pereyre, J. *J. Photochem.* **1981**, 347.
- ⁸ (a) Naciri, J.; Weiss; R.G. *Macromolecules* **1989**, *22*, 3928. (b) Naciri, J. *Ph.D. Thesis*, Georgetown University, Washington, DC, 1989.
- ⁹ (a) Brown, G. O.; Zimerman, O. E., unpublished results. (b) Naciri, J.; He, Z.; Costantino, R.M.; Lu, L.; Hammond, G.S.; Weiss, R.G. In *Multi-Dimensional NMR, FT-IR/Raman, and Fluorescence Spectroscopy of Polymers* (Symposium Series 578); Urban, M.W., Provder, T., Eds.; American Chemical Society: Washington, 1995, Chapter 25 (pp. 425-445). (c) Cui, C.; Naciri, J.; He, Z.; Jenkins, R.M.; Lu, L.; Ramesh, V.; Hammond, G.S.; Weiss, R.G. *Quimica Nova* **1993**, *16*, 578.
- ¹⁰ Lamotte, M.; Pereyre, J.; Lapouyade, R.; Jousot-Dubien, J. *J. Photochem. Photobiol. A*; **1991**, *58*, 225.
- ¹¹ Sun, Y.P.; Ma, B.; Lawson, G.E.; Bunker, C.E.; Rollins, H.W. *Anal. Chim. Acta* **1996**, *319*, 379.
- ¹² In non-PC terminology, aka 'Mother Nature'.
- ¹³ Typical topics include: (1) Can we market pyrene as a molecular frisbee?
 - (2) Should dogs be made to attend obedience classes before the end of 1999 so that they are Y2K compliant?
 - (3) Should ACS declare war on IUPAC over the names of the Lanthanide or the Actinide elements?
 - (4) Can one receive health benefits if suffering because of exciplexes?
 - (5) Is internal decay covered by most homeowner's insurance policies?
 - (6) Do heavy atoms cause obesity?
 - (7) Why do 'pesos' float and inflate so easily if they are heavy? Should they be more pesos?
- ¹⁴ In other words, we aren't sure, but we don't want to admit it.

Electron and Hole Dynamics in a Semiconductor Nanoparticle: The Importance of Interfacial Carrier Processes

C. Burda and M. A. El-Sayed

Laser Dynamics Laboratory, Department of Chemistry,
Georgia Institute of Technology,
Atlanta, GA 30332-0400, USA.

Abstract

We studied the fate and dynamics of the electron and hole created by light absorption in semiconductor nanoparticles, like CdS and CdSe. In such small particles, surface trapping becomes important. The trapping can occur by surface traps of the particle itself e.g. missing of a S^{2-} or a Cd^{2+} ion in the surface creates a hole or electron trapping site, respectively. In order to find out which is trapped first, the electron or the hole, organic electron donors or acceptors are adsorbed on the surface. The effect of such acceptors on the bleach recovery time of the exciton absorption help to assign the carrier which is rate limiting (i.e. the one with the slowest trapping rate). In this study, the rate of the electron transfer from the particle to the organic electron acceptor is determined to be 200 fs. Some acceptors, like the quinones, rapidly shuttle the electron back to the hole in the valence band. This leads to rapid band gap bleach recovery. Other acceptors, like methyl viologen in CdS does not reduce the induced hole in the particle. In this case the hole is trapped by its surface traps as in the bare particle.

1. Introduction

Semiconductor nanoparticles (NPs) have been actively studied in recent years to understand the dependence of their electronic properties on size.¹⁻³ Such NPs are large enough to build up the bulk crystal structure but too small to form continuous Bloch bands of electronic states. When the NP diameter is comparable to or smaller than the diameter of the bulk exciton (5.9 nm for CdSe) large changes in the electronic structure and properties are observed.³ The three-dimensional confinement splits the continuous band structure into a series of discrete quantum states (therefor NPs are often referred to as quantum dots). As a first consequence, the lowest optical absorption (the band gap absorption) shifts to higher energy.⁴⁻⁸ Secondly, the excited electron dynamics of such NPs change significantly.⁹⁻¹¹ For such NPs electron trapping by surface traps becomes very important in determining the electron-hole dynamics and recombination, and thus the emission characteristics of these particles. For this reason, controlled synthesis and surface modification of semiconductor NP systems is a field of considerable interest.

In this paper we summarize our studies on the CdSe NPs with naphthoquinone (NQ) and thiophenol (TP) on the surface. In addition we compare our results with the previously studied system of CdS NPs with adsorbed methylviologen (MV^{2+}). In the discussion section, the primary photochemistry of CdSe-NQ, CdS- MV^{2+} and CdSe-TP is compared.

The electron transfer from the laser-excited CdSe NP across the NP interface to an adsorbed naphthoquinone (NQ) was recently investigated.¹² It is found to be very rapid (<200 fs) and comparable to that between CdS and methyl viologen. Subsequent back electron transfer into the NP valence band occurred in the NP-Q system five

orders of magnitude faster ($\tau_{\text{rec}} = 3$ ps) than the inherent electron hole recombination in the bare CdSe NP without added acceptors ($\tau_{\text{rec}} = 100$ ns).

In a study of the dynamics of CdS NPs by Logunov et al.¹³, the hole trapping dynamics was determined by the electron removal from the excited CdS NP to the surface electron acceptor (methylviologen, MV^{2+}) and measuring the change in the rate of the bleach recovery of the band gap absorption (the bleach is recovered when the electron is removed from the conduction band and the hole is removed from the valence band). This led to a decrease in the bleach recovery time from 30 ps to 7 ps. From this result, it was concluded that the trapping of the excited electrons is the rate limiting step ($\tau_{\text{trap}} = 30$ ps) for the bleach recovery in CdS NPs.

The addition of the electron donor like thiophenol (TP) led to the neutralization of the hole in the valence band of the excited NP.¹⁴ As a result, efficient quenching of the CdSe NP emission occurred, while the bleach recovery kinetics were slowed down from 2.5 to 10 ps. The results suggest that in CdSe NPs, as in CdS NPs, electron trapping is the rate determining process ($\tau_{\text{trap}} = 40$ ps) of the bleach recovery and occurs about 10 times slower than the hole trapping.

The 4 nm diameter CdSe NP samples were prepared according to the procedure developed by Murray, et al.¹⁵ Our femtosecond transient absorption experiments were carried out with an amplified Ti-Sapphire laser system (Clark MXR CPA 1000). It was pumped by a diode-pumped, frequency-doubled Nd:Vanadate laser (Coherent Verdi). This produced laser pulses of 100 fs duration (HWFEM) and an energy of 1 mJ at 790 nm. The repetition rate was 1 kHz. A small part (4%) of the fundamental was used to focus in a 2 mm sapphire plate to generate a white light continuum which was used between 430 - 780 nm. The excitation beam was modulated by an optical chopper (HMS 221) with a frequency of 500 Hz. The probe light was split into a reference and a signal beam. The sample were irradiated in cylindrical cuvettes of 2 mm optical path length, placed in a spinning sample holder. After passing the monochromator (Acton Research) both beams were detected by two photodiodes (Thorlab). The kinetic traces were obtained using a sample-and-hold unit and a lock-in-amplifier (Stanford Research Systems). The typical measured optical density (OD) changes were in the range of 50 mOD. For spectral measurements a CCD camera (Princeton Instruments) attached to a spectrograph (Acton Research) was used. The group velocity dispersion of the white light continuum was compensated. All measurements were carried out at lowest possible laser excitation powers.

2. Results

CdSe Nanoparticles

The preparation provided 4 nm diameter NP with a standard deviation of 10% in size. The average shape is very close to spherical, although shapes with prolate deviations are observed. The absorption (dashed) and photoluminescence (solid) spectra in figure 1 confirm that a sample with relatively narrow size distribution was obtained.

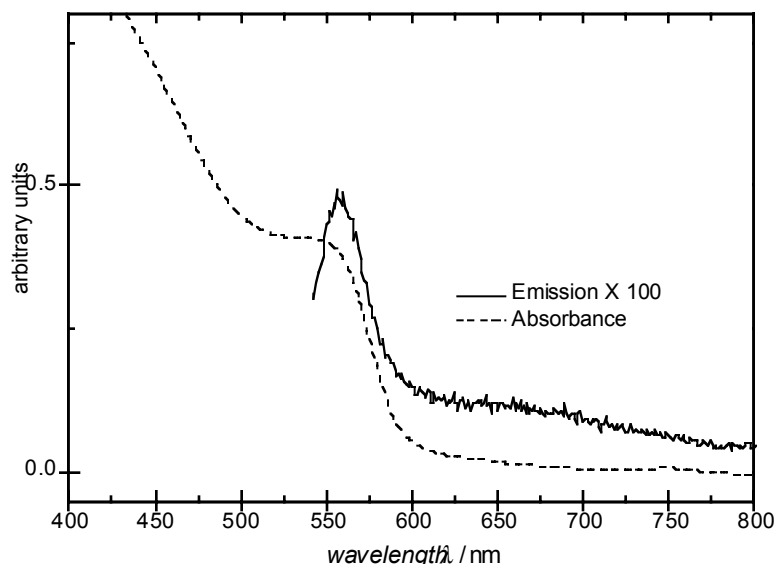

Fig. 1: Absorption (dashed) and emission spectrum (solid) of the sample shown in the TEM above. Toluene was used as solvent and the temperature was 298 K.

The absorption shows a relatively sharp onset at 580 nm. The photoluminescence has a narrow peak at 570 nm and a broad shoulder between 620 and 780 nm. The broad shoulder represents the radiative recombination of trapped charge carriers. Electrons and holes in deeper traps recombine under emission of longer wavelength photoluminescence.

CdSe-Thiophenol (electron donor)

By addition of the thiophenol (10 μ l per ml NP solution), the steady-state emission of CdSe NP was completely quenched. With femtosecond transient absorption spectroscopy, we monitored the bleach recovery of the CdSe NPs in the presence of TP. In Figure 2, the transient pump-probe spectra of the CdSe NP-TP system are

shown. The measured bleach recovery time, observed at 550 nm, became slightly longer than that in the bare NP ($\tau_1 = 10$ ps, $\tau_2 > 45$ ps versus $\tau_1 = 2.5$ ps, $\tau_2 > 40$ ps).¹⁴

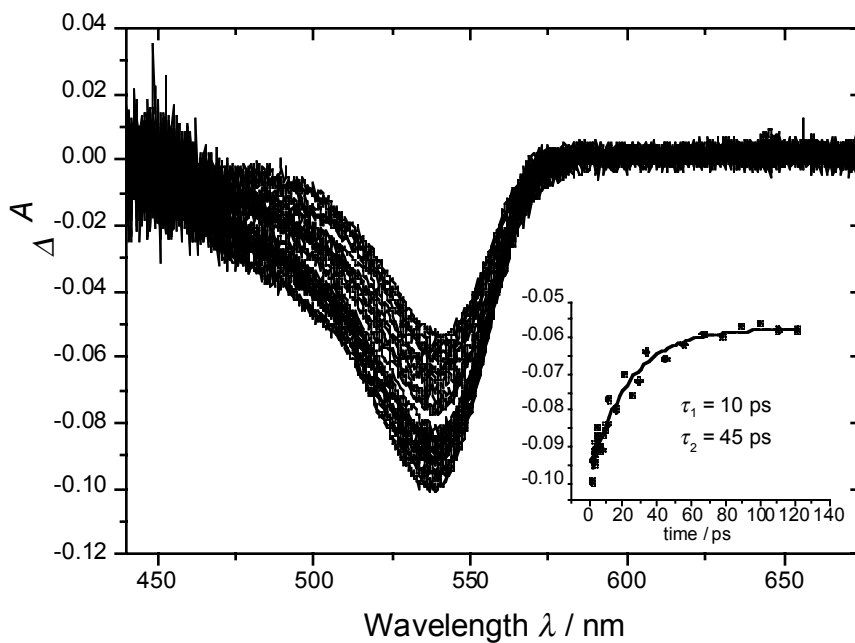

Fig. 2: The time dependence of the bleach spectra of the CdSe NP in colloidal solution with thiophenol adsorbed on its surface. The inset shows the decay of the observed bleach at its maximum 550 nm (taken from ref. (14)).

CdSe-Naphthoquinone (electron acceptor):

The addition of 1,2-naphthoquinone (NQ) to the CdSe NP suspension led to efficient quenching of the steady-state near band gap emission.¹² With femtosecond transient absorption spectroscopy, we monitored the bleach recovery of the CdSe NPs in the presence of NQ. The resulting transient femtosecond spectra of CdSe NP in the presence of NQ showed the formation of an absorption between 600 and 680 nm. This was assigned to the previously reported absorption of the radical anion of NQ. We found that the rate of formation of this radical anion absorption (200 fs, observed at 650 nm) and rate constant of the formation of the bleach (200 fs, observed at 550 nm) were identical. The formation of the band gap bleach (negative absorption) results from the relaxation of the excited electron to the lowest conduction band level. This relaxation process is in competition with the electron transfer process to the adsorbed electron acceptor.

The decay times for both the absorption of the NQ anion and the bleach recovery were the same (2.8 ps). The bleach recovery time was reduced from the approximately 100 ns in the bare CdSe NP (without quinones) to less than 3 ps in the presence of NQ. This was attributed to the electron shuttling effect of the surface quinones, which first accept the electron and subsequently shuttle it back to the hole in the NP valence band.¹²

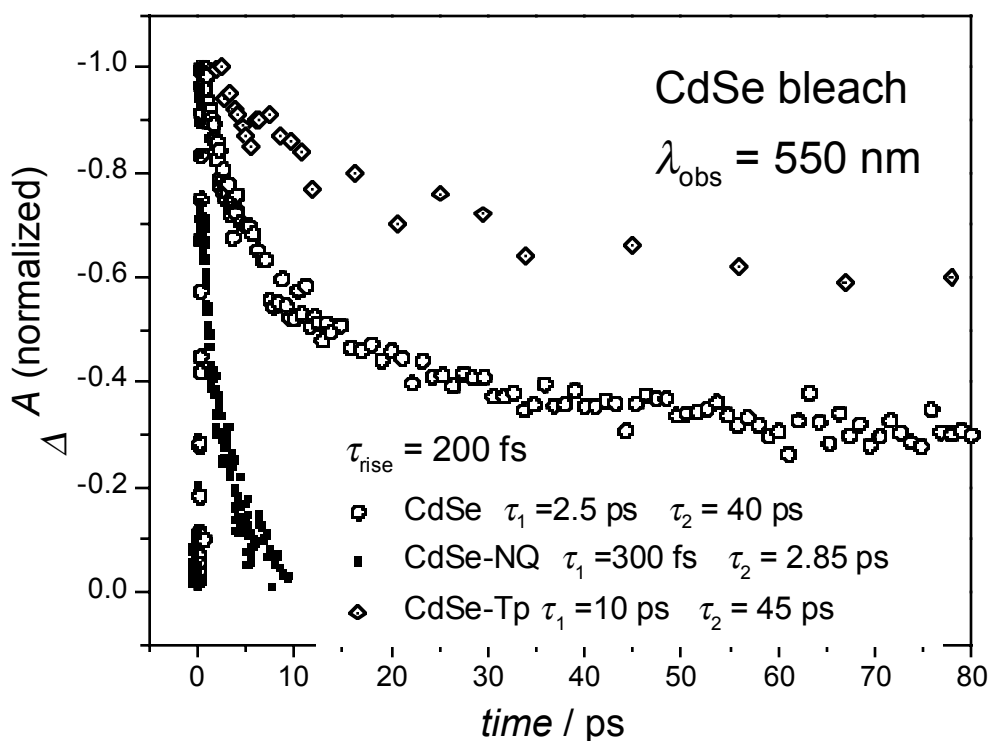

Fig. 3: The effect of the adsorption of the electron acceptor naphthoquinone (dark squares) and the electron donor thiophenol (diamonds) on the transient bleach of the CdSe NP band gap absorption (circles) at 550 nm (taken from ref. 14).

3. Discussion

The CdSe and CdS NPs exhibit different bleach spectra and dynamics. These observed differences, as well as the well-known surface effects, may be attributed to different electronic level structures of the two nanoparticles. The larger exchange interaction in CdSe causes a more complicated valence band structure and, as a result, the possibility of “dark excitons” (since the transition from the ground state to this state is spin-forbidden). Bawendi and co-workers^{5,6} have provided evidence for the dark nature of the energetically lowest exciton state of CdSe nanoparticles. These spin-forbidden states in 4 nm CdSe might decelerate the relaxation to deeply localized traps.

On the other hand, 5 nm CdS is more prone to surface deep trapping. This might result from energetically low-lying surface states, due to surface imperfection on the CdS NP. The efficient charge carrier localization in 5 nm CdS is revealed by the rapid spectral diffusion. The differences in electronic and surface structure contributes significantly to the observed difference in the dynamics.

Effects of electron donors (TP) and electron acceptors (NQ) on the charge carrier relaxation in CdSe

In this section, the effects of the TP electron donor and the NQ electron acceptor on the carrier dynamics of the CdSe interface are discussed. The observed emission quenching of CdSe nanoparticle by TP suggests that the TP neutralizes the holes in the valence band of the photoexcited CdSe, thus inhibiting electron-hole recombination. This charge transfer across the CdSe interface and subsequent neutralization of the valence band hole is also responsible for the slowing of the bleach recovery relative to the bare nanoparticle. The TP might bind to electron trap sites and thus slows down the fast electron trapping processes. If the electron relaxation dynamics is rate limiting for the bleach recovery, one can explain the observed decrease in the rate of the bleach recovery by TP. The Stokes-shifted photoluminescence in the 4 nm gives evidence that the emission results from surface traps. The multi-exponential decay traces of the pure nanoparticle indicate competitive kinetics between internal state relaxation and surface trapping.

NQ is a classical electron acceptor. By-passing of the internal dark states of CdSe accelerates the electron relaxation by shuttling the electron from the conduction band across the interface to NQ in less than 200 fs and from there back into the valence band in < 3 ps. The electron shuttling effect of the NQ is revealed by the faster bleach recovery dynamics in comparison to that in the bare CdSe. We also observed the formation and decay of the NQ radical anion.¹² Since shuttling of the electron accelerates the bleach recovery, it can be concluded that the electron dynamics is rate limiting in the relaxation processes of CdSe, similar as that observed in CdS.¹³ An interesting aspect of these results is that the charge separation across the CdSe interface by NQ reduces the overlap of the charge carrier wavefunctions, allowing in this case faster relaxation since the driving force favors the charge recombination and simultaneously the exchange interaction is minimized.¹⁴

The reduction of the hole by the TP on CdSe introduces an unfavorable localization of the hole, which slows the relaxation dynamics even more. Additional surface effects cannot be excluded either. For example, the addition of TP could eliminate electron traps on the CdSe NP surface.

Electron transfer via the CdSe NP interface is demonstrated in both directions, from and to surface molecules. The comparison of the effects of the addition of the electron donor (TP) with the effect of the addition of the electron acceptor (NQ) to the NP on the electron-hole dynamics leads to the following conclusion: The added organic components on NP surfaces can act either as an efficient electron shuttle that accelerates the charge carrier recombination (e.g. NQ on CdSe), as electron robber that takes the electron but does not give it back to the particle and change the relaxation pathway of the photoexcited electron (MV²⁺ on CdS), or as electron donor and hole trap that slows down the relaxation process (TP on CdSe).

Figure 4 summarizes the proposed electron transfer mechanisms for the different composite systems.

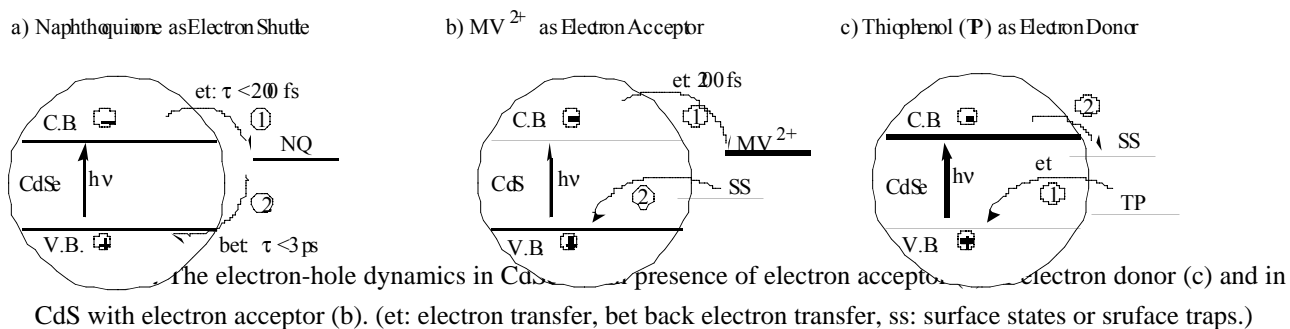

In (a), the relaxation of the excited electron (step 1) and its combination with the hole (step 2) in the valence band (which leads to bleach recovery) occurs via the NQ and by-passes surface trapping and/or changes in the state multiplicity. As a result an acceleration of the bleach recovery is observed.

The electron-hole dynamics in the CdS-MV²⁺ system is summarized in (b). In this case, the electron is rapidly transferred from the conduction band of the NP to the electron acceptor (MV²⁺) (step 1). In aerated solution at room temperature, the MV⁺ does not shuttle the electron back to the hole in the valence band. The hole is thus trapped in 7 ps by the surface states (step 2). This led to the conclusion that the observed bleach recovery time of 30 ps in the bare NP must be rate determined by the electron trapping and not by the hole trapping.

In (c), the hole in the valence band of the excited CdSe particles is first neutralized by the electron transfer from the electron donor (step 1). The removal of the excited electron (and thus the bleach recovery) takes place by surface trapping (step 2). The fact that the bleach recovery is not greatly affected by the addition of TP suggests that surface trapping in the CdSe NP is faster than the back electron transfer from the NP conduction band to the TP. It is then concluded, that the bleach recovery in the CdSe NP, like that in the CdS NP, is rate determined by the electron and not by the hole trapping.

Acknowledgements

The authors wish to thank T. Green and S. Link for their collaboration in this work. The continued support of this work by the Office of Naval Research (ONR grant No. N00014-95-1-0306) is greatly appreciated.

References

1. A. Henglein, *Chem. Rev.* 1989, 89, 1861.
2. A. P. Alivisatos, *J. Phys. Chem.* 1996, 100, 13226.
3. L. E. Brus, *J. Chem. Phys.* 1983, 79, 5566.
4. M. G. Bawendi, P. J. Carroll, W. L. Wilson, L. B. Brus, *J. Chem. Phys.* 1992, 96, 946.
5. M. Nirmal, D. J. Norris, M. Kuno, M. G. Bawendi, A. L. Efros, M. Rosen, *Phys. Rev. Lett.* 1995, 75, 3728.
6. A. L. Efros, M. Rosen, M. Kuno, M. Nirmal, D. J. Norris, M. G. Bawendi, *Phys. Rev. B* 1996, 54, 4843.
7. M. Kuno, J. K. Lee, B. O. Dabousi, F. V. Mikulec, M. G. Bawendi, *J. Chem. Phys.* 1997, 106, 9869.
8. B. O. Babbouni, J. Rodriguez-Viejo, F. V. Mikulec, J. R. Heine, H. Mattoussi, R. Ober, K. F. Jensen, M. G. Bawendi, *J. Phys. Chem. B* 1997, 101, 9463.
9. Alivisatos, A.P.; Harris, A.L.; Levinos, N.J.; Steigerwald, M.L.; Brus, L.E.; *J. Chem. Phys.* 1988, 89, 4001.
10. Bawendi, M.G.; Wilson, W.L.; Rothberg, L.; Carroll, P.J.; Jedju, T.M.; Steigerwald, M.L.; Brus, L.E.; *Phys. Rev. Lett.* 1990, 65, 1623.
11. Hunsche, S.; Dekorsy, T.; Klimov, V.; and Kurz, H. *Appl. Phys. B* 1996, 62, 3.
12. C. Burda, T. C. Green, S. Link, M. A. El-Sayed, *J. Phys. Chem. A* 1999, 103, 1783.
13. S. Logunov, T. Green, T. S. Marguet, M. A. El-Sayed, *J. Phys. Chem. A* 1998, 102, 5652.
14. Burda, C.; Link, S.; Green, T.C.; El-Sayed M.A. *Microcrystalline and Nano-crystalline Semiconductors*, MRS Proceedings 1998.
15. C.B.Murray, D. J. Norris, M. G. Bawendi, *J. Am. Chem. Soc.* 1993, 115, 8706.
16. C. Burda, R. B. Little, S. Link, T. C. Green, M. A. El-Sayed, *Society for Optical & Quantum Electronics Proceedings* 1998.

**6th Latin American Encounter for Photochemistry and Photobiology
(ELAFOT-6)**

**September 12 - 16, 1999
Hotel Fazenda São Moritz, Teresópolis, Rio de Janeiro, Brasil**

Fourth Circular

Registration for the meeting can be done by sending a filled out application form together with payment to the

Local Organizing Committee - ELAFOT-6
Attention: Prof. Ira M. Brinn
Instituto de Química - UFRJ
Caixa Postal 68.563 - Ilha do Fundão
Rio de Janeiro, R. J. 21.941-970 Brasil

or via FAX (055-021-290-4746). In this case payment can be made by direct deposit in the account of the "Associação dos Ex-alunos do IQ/UFRJ - ELAFOT-6", account No. 5005203-3, Banco Real (Bank No. 275), Agency No. 0896, Rio de Janeiro, RJ, Brasil. Please include a copy of the deposit slip with the faxed form.

Abstracts (in Portuguese, Spanish or English) should follow the following format: one complete page, A4 (21 cm x 29.6 cm), all margins - 3 cm, source - Times New Roman, letter size - 14, spacing - single. The order should be; 1) Title (all capital letters, centered) skip line, 2) Authors (underline name of author presenting the work, centered) skip line, 3) Address and e-mail (of author presenting the work, centered) skip line 4) Body of Abstract (justified). The Abstracts should be submitted (preferentially) electronically to the e-mail address given below or via airmail, in WORD or RTF.

Activities will commence at 4:00 PM on Sunday, September 12, 1999, with distribution of material, etc. The meeting will officially begin on Monday morning at 8:30 AM and go until Thursday, lunchtime. There will be twelve sessions of oral presentations and two poster sessions.

Information and forms: <http://www.iq.ufrj.br/elafot6>
Or IRABRINN@IQ.UFRJ

Upcoming Meetings

An up-to-date version of this list is posted on the I-APS website (<http://www.chemistry.mcmaster.ca/~iaps/index.html>). Please send new meeting announcements to: wsjenks@iastate.edu and iaps@mcmaster.ca.

◆ **FUNCTIONAL DYES 4TH INTERNATIONAL SYMPOSIUM ON FUNCTIONAL DYES SCIENCE AND TECHNOLOGY OF FUNCTIONAL *PI* ELECTRON SYSTEMS**

May 31 – June 4, 1999

Osaka, Japan

Information: Prof. Yasuhiko Shirota, Faculty of Engineering, Osaka University, Yamadaoka, Suita, Osaka, Japan 565-0871, Japan, Tel.: +81 6 879 7364, Fax: +81 6 879 7367, email: isfd@chem.eng.osaka-u.ac.jp.

◆ **13TH ISPPCC, INTERNATIONAL SYMPOSIUM ON PHOTOCHEMISTRY AND PHOTOPHYSICS OF COORDINATION COMPOUNDS**

June 26 – July 1, 1999

Isle of Lipari, Sicily, Italy

Information: Dr. Sebastiano Campagna, Dept. of Inorganic, Analytical and Physical Chemistry, University of Messina, Via Sperone, 31, I-98166 S. Agata, Messina, tel: 39 90/676 57 37, fax: +39 90/39 37 56, email: isppcc@chem.unime.it.

◆ **6TH CONGRESS OF THE INTERNATIONAL SOCIETY FOR SKIN IMAGINE**

July 4 – 6, 1999

London, England

Information: J. C. Bamber, email: hitec@rpms.ac.uk

◆ **ISES 1999 SOLAR WORLD CONGRESS**

July 4 – 9, 1999

Jerusalem, Israel

Information: ISES 1999 Solar World Congress Secretariat, P.O. Box 50006, Tel Aviv 61500, Israel, tel: +972 3/514 00 00, fax: +972 3/514 00 77, email: ises99@kenes.com

◆ **2ND INTERNET PHOTOCHEMISTRY AND PHOTOBIOLOGY CONFERENCE**

July 16 – September 7, 1999

Information: Paul Heelis. 2nd virtual meeting on photochemistry and photobiology. Latest details at <http://www.photobiology.com/photo99/> Paper or poster submission may be done on-line at <http://www.photobiology.com/photo99register.htm> or send an email with the details to paul@infochem.co.uk. Papers will be treated as submissions to J. Photochem. Photobiol. B and published in print after the normal refereeing process. Posters will be displayed for the conference duration and then just the abstract retained, authors are free to publish elsewhere. Deadline for guaranteed inclusion in the conference: June 18. Papers and posters submitted after that date may be included subject to workload.

◆ **1999 ORGANIC PHOTOCHEMISTRY – GORDON RESEARCH CONFERENCE**

July 17 – 22, 1999

Connecticut College, New London, CT U.S.A.

Information: Prof. I. R. Gould, Arizona State University, Department of Chemistry and Biochemistry, Tempe, AZ 95287-1604; tel: (602) 965-7278; fax: (602) 965-2747; email: igould@asu.edu or Prof. R. S. Given, University of Kansas, Department of Chemistry, Lawrence, KS 66045; tel: (785) 864-3486; fax: (785) 864-5296; email: rgiven@ukans.edu Registration information may also be obtained on-line at <http://www.public.asu.edu/~iangould/grc/grc99.html>

◆ **FEMTOCHEMISTRY IV 1999**

July 18 – 22, 1999

Leuven, Belgium

Information: Prof. Dr. F. C. De Schryver, K. U. Leuven, Celestijnenlaan 200F, B-3001 Heverless, Belgium, tel: +32 16/32 74 05, fax: +32 16/32 79 89, email: frans.deschryver@chem.kuleuven.ac.be

◆ **10TH IUPAC SYMPOSIUM ON ORGANO-METALLIC CHEMISTRY DIRECTED TOWARDS ORGANIC SYNTHESIS**

July 18 - 22, 1999

Versailles, France

Information: Congres Scientifiques Services (C2S), Chantal Iannarelli, 2 rue des Villarmains, B.P. 124, F-92210 Saint-Cloud, tel: 33(0)147719004, fax: 33(0)147719005, email: c2s@club-internet.fr

◆ **XIXTH INTERNATIONAL CONFERENCE ON PHOTOCHEMISTRY**

August 1 - 6, 1999

Duke University, Durham, NC, U.S.A.

Information: Prof. John D. Simon, Dept. of Chemistry, Duke University, Durham, NC 27708, email: icp99@chem.duke.edu, jds@chem.duke.edu or <http://www.chem.duke.edu/~icp99>

◆ **8TH EUROPEAN CONFERENCE ON THE SPECTROSCOPY OF BIOLOGICAL MOLECULES**

August 29 – September 2, 1999

University of Twente, Netherlands

Information: Prof. J. Greve, Univ. of Twente, POB 217, NL-7500 AE Enschede, phone: x31-53-489-3157, fax: x31-53-489-1105, email: j.greve@tn.utwente.nl

◆ **6TH INTERNATIONAL CONFERENCE ON METHODS AND APPLICATIONS OF FLUORESCENCE SPECTROSCOPY**

September 12 - 15, 1999

Paris, France

Information: MAFS6, Prof. Bernard Valeur, Conservatoire National des Artes et Metiers, 292 rue Saint-Martin, F-75141 Paris Cedex 03, tel: 33(0)140272389, fax: x33(0)140272362, email: mafs6@cnam.fr

◆ **6TH LATIN AMERICAN ENCOUNTER FOR PHOTOCHEMISTRY AND PHOTOBIOLOGY (ELAFOT-6)**

September 12 - 16, 1999

Rio de Janeiro, Brazil

Information: Prof. Ira M. Brinn, Univ. Federal do Rio de Janeiro, Brazil, email: irabrinn@iq.ufrj.br

◆ **9TH RADTECH EUROPE CONFERENCE AND EXHIBITION**

November 8 – 10, 1999

Berlin, Germany

Information: Vincentz Verlag, Schiffgraben 43, D-30175 Hannover, tel: +511/9910-271, fax: /9910-279

◆ **11TH INTER-AMERICAN PHOTOCHEMICAL SOCIETY WINTER CONFERENCE**

January 2-6, 2000

Clearwater Beach, FL U.S.A.

Information: Dr. Edwin F. Hilinski, Florida State University, fax: 850-644-8281; email: hilinski@chem.fsu.edu or Dr. Joseph T. Hupp, Northwestern University, fax: 847-492-7713; email: jthupp@chem.nwu.edu or information may be obtained from the Inter-American Photochemical Society web site at <http://www.chemistry.mcmaster.ca/~iaps>

◆ **IXTH INTERNATIONAL SYMPOSIUM ON LUMINESCENCE SPECTROMETERY IN BIOMEDICAL AND ENVIRONMENTAL ANALYSIS. SPECTROSCOPIC AND IMAGING DETECTION TECHNIQUES**

May 15 - 17, 2000

Montpellier, France

Information: Prof. Dan A. Lerner, Univ. of Montpellier, ENSC, 8 Rue de l'Ecole Normale, F-34296 Montpellier cedex 5, tel: x33/04 6714 4323, fax: x33/04 6714 4349, email: lerner@enscm.fr

◆ **PHOTOBIOLOGY 2000: JOINT CONGRESS (AIP), ASP AND ESP MEETING**

May 31 – June 4, 2000

San Francisco, CA U.S.A.

Information: Nancy L. Oleinick, Biomedical Res Bldg 3, Case Western Reserve University, 10900 Euclid Avenue, Cleveland, OH 44106-4942, tel: +1 216/368 1117, fax: +1 216/368 1142, email: nlo@po.cwru.edu

◆ **XVIII IUPAC SYMPOSIUM ON PHOTOCHEMISTRY**

July 22 – 27, 2000

Dresden, Germany

Information: Prof. Silvia Braslavsky, Mülheim, fax: +49 208/306 39 51, email: braslavskys@mpi-muelheim.mpg.de (chairperson); Prof. Thomas Wolff, Dresden, fax: +49 351/463 33 91, email: wolff@cech01.chm.tu-dresden.de (chairman local committee).

Please indicate your general area of Photochemistry interest below:

Physical	_____	Inorganic	_____	Physical Organic	_____
Organic	_____	Analytical	_____	Photophysics	_____
Theoretical	_____	Photobiology	_____		

Please check specific Photochemistry interests:

<input type="checkbox"/> Air Pollution (AP)	<input type="checkbox"/> Photochemical Kinetics (PK)
<input type="checkbox"/> Atmospheric (AT)	<input type="checkbox"/> Spectroscopy (SP)
<input type="checkbox"/> Chemiluminescence (CL)	<input type="checkbox"/> Photoemission (PE)
<input type="checkbox"/> Dyes (CD)	<input type="checkbox"/> Isotope Separation (IS)
<input type="checkbox"/> Environmental (CE)	<input type="checkbox"/> Photobiochemistry (BC)
<input type="checkbox"/> Extraterrestrial (ET)	<input type="checkbox"/> Photobiophysics (BP)
<input type="checkbox"/> Far UV (UV)	<input type="checkbox"/> Photochromism (PC)
<input type="checkbox"/> Imaging Systems (Silver) (PG)	<input type="checkbox"/> Photoconductivity (PN)
<input type="checkbox"/> Imaging Systems (Nonsilver) (RG)	<input type="checkbox"/> Photoelectrochemistry (PL)
<input type="checkbox"/> Lasers (LS)	<input type="checkbox"/> Photoionization (PI)
<input type="checkbox"/> Macromolecular (CC)	<input type="checkbox"/> Photolithography (PT)
<input type="checkbox"/> Mechanistic (MP)	<input type="checkbox"/> Photomedicine (PM)
<input type="checkbox"/> Ordered Media (OM)	<input type="checkbox"/> Photosynthesis (PS)
<input type="checkbox"/> Organometallic (CM)	<input type="checkbox"/> Radiation Chemistry (RC)
<input type="checkbox"/> Preparative/Synthetic (CR)	<input type="checkbox"/> Solar Energy Utilization (SE)
<input type="checkbox"/> Polymer (CY)	<input type="checkbox"/> Vision (VS)